

AWEASY



Advantages

- The reliable AW Quick mode for quick results (typical 4 - 5 min)
- Easy use with a Smartphone App for iOS and Android
- Standalone measuring device with light ring and display
- Long battery life with wireless charging

Applications

- Food Industry
- Pharmaceutical Industry
- Chemical Industry
- Cosmetics Industry



General Information

Measurement

- AW Quick functions for quick results within 4 to 5 minutes
- Normal aw measurements in about 50 minutes

Connecting

- Easy connection via Bluetooth and App
- Magnetic attachment for the wireless charger

App Functions

- Changing the measuring settings and modes of the measurement head
- Automatic generation and saving of a report after each measurement
- Direct downloads of the measurement reports
- Firmware Update

Stable housing

- Use of robust materials such as aluminum and stainless steel
- Display and light ring indicator for the status



AwEasy with the wireless charger

AwEasy and WP-40



Accessories

Sample holders and sample containers



The sample holders provide excellent sample containment and optimum temperature stability. The WP-40TH can be attached to a water bath for additional temperature control. The disposable sample containers ensure the optimum sample volume is introduced into

the sample holders. They prevent the sample holders from coming into direct contact with the product being tested, thereby preventing soiling or cross contamination. The sample containers also provide a convenient means of collecting and storing samples.

Sample holders

Order code	WP-14-S	WP-40	WP-40TH
			
Use with	PS-14	PS-14/PS-40	PS-14/PS-40
Height	14 mm	40 mm	40 mm
Material	V2A steel		Brass, nickel-plated
Weight	350 g	1250 g	1550 g

Sample container

Order code	PS-14	PS-40
		
Use with	WP-14-S/WP-40/WP-40TH	WP-40/WP-40TH
Height	14 mm	40 mm
Packaging unit	100 pc.	

Technical Data

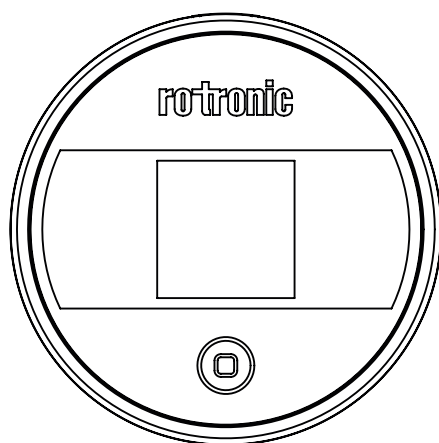
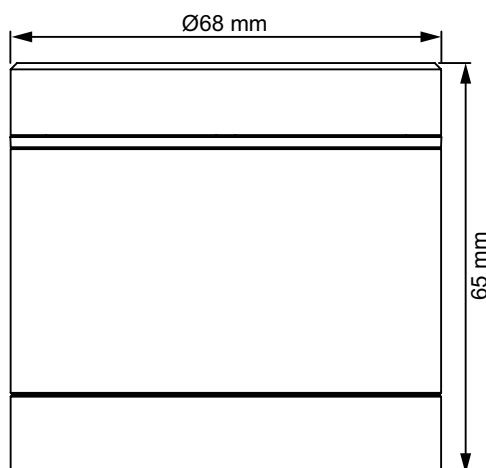

Sensor	HYGROMER WA-1
Accuracy @ 23 ±5 °C	± 0.008 aw / 0.8 %rh / ±0.1 K
Operating conditions	0...70 °C / 0...100%rh
Storage conditions	-10...70 °C / 0...100 %rh
Parameters shown	aw, %rh, °C, °F
Status light	Yes
Long-term stability	< 1 %rh / year (normal conditions)
AW Quick Mode	Yes
Display	1.2" LCD color display
Button	Multifunctional touch button
Trend display	Yes
Clock	Real time clock provides a time stamp for every measurement
Batterie capacity	500 mAh
Power supply	5 V DC 1.5A 7.5 W max (AC adapter)
Power supply plugs	US / EU & UK
USB cable	USB-A to USB-C
Firmware update	Direct over the App
Protocols (values)	Date, time, aw / rh / °C / °F, aw setpoint, serial no., etc.
HygroSoft and HygroLab compatibility	No
Acoustic alarm	No
Calculations	No psychrometric calculations available
Dimensions	Ø68 x 65 mm
Housing material	Aluminum, stainless steel & PC
Weight	600 g
CE conform	CE 2014/30/EU
IP protection rating	IP65

Subject to technical change without notice. Printing and other errors reserved.