

Pressure balance

High-pressure version

Model CPB5000HP



WIKA data sheet CT 31.51



for further approvals
see page 5

Applications

- Primary standard for representing the pressure scale in a hydraulic range up to 5,000 bar (70,000 psi)
- Reference instrument for factory and calibration laboratories for the testing, adjustment and calibration of pressure measuring instruments
- Complete, stand-alone system, also suitable for on-site use

Special features

- Total measurement uncertainty to 0.02 % of reading
- Factory calibration included as standard, traceable to national standards; with DKD/DAkkS calibration possible as an option
- High long-term stability with recommended recalibration interval every five years
- Masses manufactured from stainless steel and aluminium, can be adjusted to local gravity

Description

Proven primary standard

Pressure balances (dead-weight testers) are the most accurate instruments available on the market for the calibration of electronic or mechanical pressure measuring instruments. The direct measurement of the pressure ($p = F/A$), as well as the use of high-quality materials enable a very small measurement uncertainty, in conjunction with an excellent long-term stability.

The pressure balance (dead-weight tester) has therefore been used for years in factory and calibration laboratories in industry, national institutes and research laboratories.

Stand-alone operation

Due to its integrated pressure generation and the purely mechanical measuring principle, the model CPB5000HP is ideal for on-site use for maintenance and service.



Pressure balance, high-pressure version,
model CPB5000HP

Basic principle

Pressure is defined as the quotient of force and area. The core component of the CPB5000HP is therefore a very precisely manufactured piston-cylinder system, onto which a mass load is applied in order to generate the individual test points.

The mass load is proportional to the target pressure and this is achieved through optimally graduated masses. As standard, these masses are manufactured to the standard gravity (9.80665 m/s^2), though they can be adjusted to a specific location and also DKD/DAkkS calibrated.

Easy operation

The setting of the pressure is made via an integrated pump. For fine adjustment, a very precisely controllable spindle pump is fitted, with a spindle running within it. As soon as the measuring system reaches equilibrium, there is a balance of forces between the pressure and the masses applied. The excellent quality of the system ensures that this pressure remains stable over several minutes, so that the pressure value for comparative measurements can be read without any problems, or also so that more complex adjustments can be carried out on the test item.

The piston-cylinder system

Both the piston and cylinder are manufactured from hardened steel or tungsten carbide, respectively. These pairings of materials, in comparison to other materials, have very low pressure and temperature coefficients of expansion, which results in a very good linearity for the effective area of the piston and a very high accuracy.

The overall design of the piston-cylinder system and the very precise manufacturing of both the piston and the cylinder, ensures excellent operating characteristics with long free-rotation time and low sink rates. Thus a high long-term stability is ensured. Therefore, the recommended recalibration interval is two to five years dependent on the conditions of use.

Tables of masses

The following tables show the number of masses within a mass set with their nominal mass values and the resulting nominal pressures for the respective measuring ranges. Should the instrument not be operated under reference conditions (ambient temperature 20 °C (68 °F), atmospheric pressure 1,013 mbar (14.69 psi), relative humidity 40 %), the measured values must be corrected arithmetically.

Robust instrument design

With the high-pressure model, calibrations up to a maximum of 5,000 bar (70,000 psi) are possible. It is built into a stable base and offers exceptional ease-of-use. With the integrated priming pump and the 250 ml tank, large test volumes can also be easily filled and primed.

Both test connections are fitted with knurled nuts and exchangeable thread adapters with sealing cones. M16 x 1.5, M20 x 1.5 and 9/16-18 UNF thread adapters with male threads are included in the scope of delivery.

For the measurement of the ambient conditions, the CPU6000 CalibratorUnit can be used, see page 6.

The masses are manufactured, as standard, to the standard gravity (9.80665 m/s²) although they can be adjusted for any local gravity.

Measuring range	25 ... 2,500 bar		25 ... 4,000 bar		25 ... 5,000 bar	
	Quantity	Nominal pressure per piece in bar	Quantity	Nominal pressure per piece in bar	Quantity	Nominal pressure per piece in bar
Piston incl. mass carrier	1	25	1	25	1	25
Masses 5 kg	-	-	6	250	10	250
Masses 4 kg	8	200	8	200	8	200
Masses 2 kg	9	100	9	100	9	100
Masses 1 kg	1	50	1	50	1	50
Masses 0.5 kg	2	25	2	25	2	25
Masses 0.2 kg	1	10	1	10	1	10
Masses 0.1 kg	1	5	1	5	1	5
Masses 0.05 kg	1	2.5	1	2.5	1	2.5

Measuring range	350 ... 40,000 psi		350 ... 60,000 psi		350 ... 70,000 psi	
	Quantity	Nominal pressure per piece in psi	Quantity	Nominal pressure per piece in psi	Quantity	Nominal pressure per piece in psi
Piston incl. mass carrier	1	350	1	350	1	350
Masses 7 kg	2	5,000	6	5,000	8	5,000
Masses 3.5 kg	8	2,500	8	2,500	8	2,500
Masses 1.4 kg	8	1,000	8	1,000	8	1,000
Masses 1 kg	1	750	1	750	1	750
Masses 0.7 kg	2	500	2	500	2	500
Masses 0.35 kg	1	250	1	250	1	250
Masses 0.14 kg	1	100	1	100	1	100
Masses 0.07 kg	1	50	1	50	1	50

Specifications Model CPB5000HP

Piston-cylinder system			
Measuring range ¹⁾	25 ... 2,500 bar	25 ... 4,000 bar	25 ... 5,000 bar
Required masses	50 kg	80 kg	100 kg
Smallest step ²⁾ (Standard mass set)	2.5 bar	2.5 bar	2.5 bar
Nominal effective area of the piston	0.02 cm ²	0.02 cm ²	0.02 cm ²
Measuring range ¹⁾	350 ... 40,000 psi	350 ... 60,000 psi	350 ... 70,000 psi
Required masses	55 kg	83 kg	97 kg
Smallest step ²⁾ (Standard mass set)	50 psi	50 psi	50 psi
Nominal effective area of the piston	0.02 cm ²	0.02 cm ²	0.02 cm ²
Accuracies			
Standard ^{3) 4)}	0.025 % of reading		
Premium ^{3) 4)}	0.02 % of reading		
Pressure transmission medium	to 4,000 bar / 60,000 psi: Hydraulic fluid based on VG22 mineral oil (1 litre included in scope of delivery) 5,000 bar / 70,000 psi: Sebacate oil (0.5 litres included in scope of delivery)		
Material			
Piston	Hardened steel		
Cylinder	Tungsten carbide		
Piping in base	1.4404 stainless steel, 6 x 2 mm		

- 1) Theoretical starting value; corresponds to the pressure value generated by the piston (by its own weight). To optimise the operating characteristics more masses should be loaded.
- 2) The smallest pressure change value that can be achieved based on the standard mass set. To reduce this, a set of fine increment masses is also available.
- 3) The accuracy from 10 % of the measuring range is based on the measured value. In the lower range, a fixed error based on 10 % of the range applies.
- 4) Measurement uncertainty assuming reference conditions (ambient temperature 20 °C (68 °F), atmospheric pressure 1,013 mbar (14.69 psi), relative humidity 40 %). For operation without a CalibratorUnit, corrections must be made if required.

Piston-cylinder system**Weight**

Piston-cylinder system	2.7 kg / 5.0 kg (6.0 lbs / 11.0 lbs) (incl. storage case)		
bar basic mass set, carrying case 1	34.0 kg (75.0 lbs)	34.0 kg (75.0 lbs)	34.0 kg (75.0 lbs)
bar basic mass set, carrying case 2	27.5 kg (60.6 lbs)	27.5 kg (60.6 lbs)	27.5 kg (60.6 lbs)
bar extension mass set, carrying case 1	--	33.5 kg (73.9 lbs)	33.5 kg (73.9 lbs)
bar extension mass set, carrying case 2	--	--	23.5 kg (51.8 lbs)
psi basic mass set, carrying case 1	51.0 kg (112.5 lbs)	51.0 kg (112.5 lbs)	51.0 kg (112.5 lbs)
psi basic mass set, carrying case 2	15.0 kg (33.1 lbs)	15.0 kg (33.1 lbs)	15.0 kg (33.1 lbs)
psi extension mass set, carrying case 1	--	31.8 kg (70.1 lbs)	31.8 kg (70.1 lbs)
psi extension mass set, carrying case 2	--	--	17.8 kg (39.2 lbs)

Dimensions (W x D x H)

Carrying case 1 for basic mass set	400 x 310 x 310 mm (15.7 x 12.2 x 12.2 in)
Carrying case 2 for basic mass set	215 x 310 x 310 mm (8.5 x 12.2 x 12.2 in)
Carrying case for extension mass set	215 x 310 x 310 mm (8.5 x 12.2 x 12.2 in)
Storage case for the piston-cylinder system	370 x 150 x 150 mm (14.6 x 5.9 x 5.9 in)

Base

Pressure transmission medium	to 4,000 bar / 60,000 psi: Hydraulic fluid based on VG22 mineral oil (1 litre included in scope of delivery) 5,000 bar / 70,000 psi: Sebacate oil (0.5 litres included in scope of delivery)
Reservoir	250 cm ³

Connections

Connection for piston-cylinder system	M30 x 2 female with sealing cone
Test item connection	Freely positionable, standard with three thread adapters, M16 x 1.5, M20 x 1.5 and 9/16-18UNF for further thread adapters, see Accessories

Material

Piping in base	1.4404 stainless steel, 6 x 2 mm
----------------	----------------------------------

Weight

High-pressure base	32.5 kg (71.7 lbs)
--------------------	--------------------



Permissible ambient conditions

Operating temperature	18 ... 28 °C (64 ... 82 °F)
-----------------------	-----------------------------

Dimensions (W x D x H)

Base	460 x 445 x 265 mm (18.1 x 17.5 x 10.4 in), for details, see technical drawings
------	---

Approvals

Logo	Description	Country
	EC declaration of conformity Pressure equipment directive <ul style="list-style-type: none"> ■ 97/23/EC, module A (valid until 2016-07-18) ■ 2014/68/EU, module A (valid from 2016-07-19) 	European Community
	Uzstandard Metrology, measurement technology	Uzbekistan
-	MTSCHS Permission for commissioning	Kazakhstan

Certificates

Certificate	
Calibration	Standard: 3.1 calibration certificate per DIN EN 10204 Option: DKD/DAkkS calibration certificate
Recommended recalibration interval	2 to 5 years (dependent on conditions of use)

Approvals and certificates, see website

Transport dimensions for complete instrument

The complete instrument, in its standard version and standard scope of delivery, is shipped on two pallets. The dimensions are 1,200 x 800 x 500 mm (47.3 x 31.5 x 19.7 in) and 800 x 600 x 500 mm (31.5 x 23.6 x 19.7 in). The overall weight is dependent on the measuring range.

Version in bar	Weight	
	net	gross
25 ... 2,500 bar	100 kg (220.5 lbs)	130 kg (286.7 lbs)
25 ... 4,000 bar	133 kg (293.3 lbs)	166 kg (366.0 lbs)
25 ... 5,000 bar	156 kg (344.0 lbs)	194 kg (427.8 lbs)

Version in psi	Weight	
	net	gross
350 ... 40,000 psi	104 kg (229.3 lbs)	134 kg (295.5 lbs)
350 ... 60,000 psi	136 kg (299.9 lbs)	169 kg (372.6 lbs)
350 ... 70,000 psi	153 kg (337.4 lbs)	191 kg (421.2 lbs)

Dimensions in mm (in)

Front view

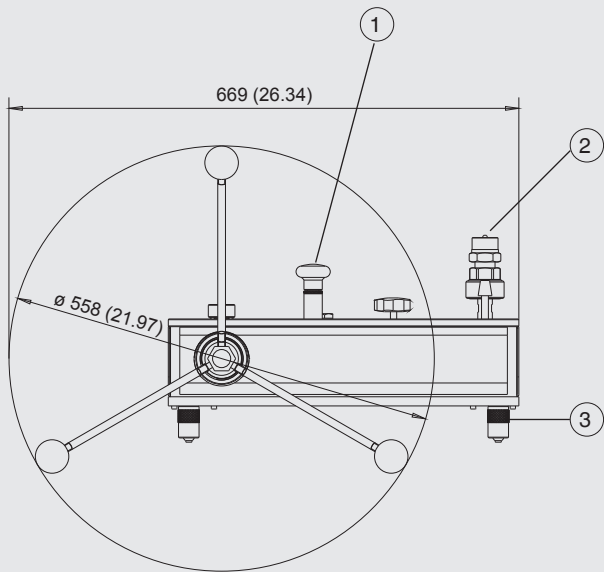

Side view (left)

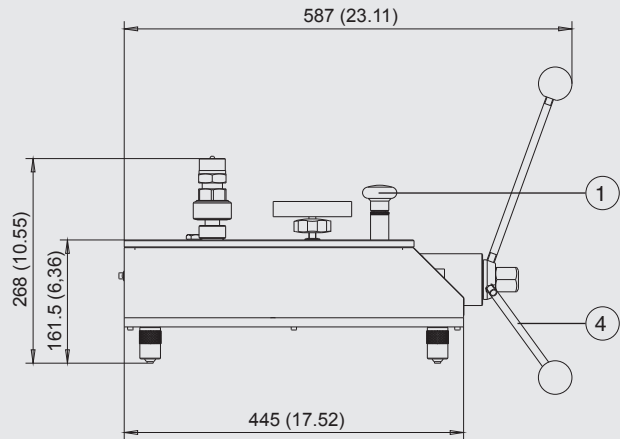

Top view

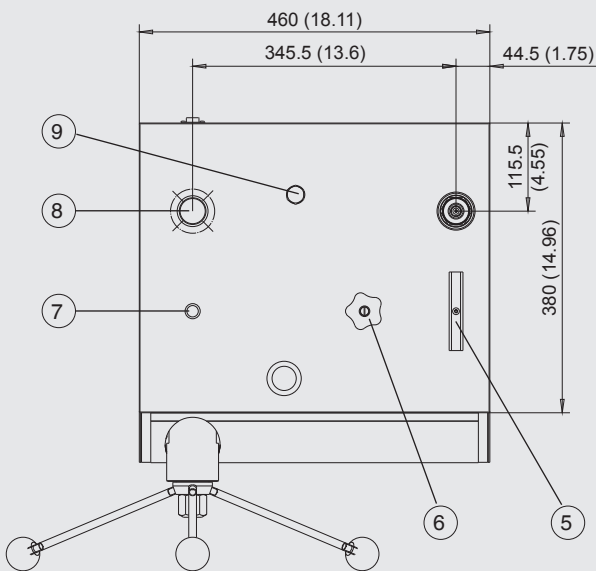

Test item connection

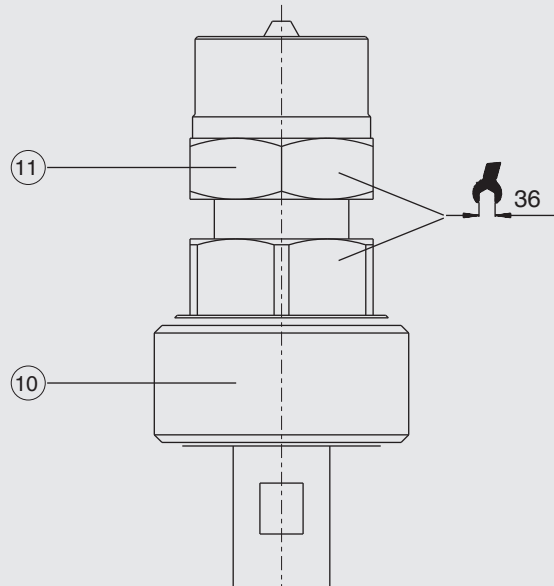

- ① Priming pump
- ② Test item connection
- ③ Rotatable feet
- ④ Spindle pump with star handle
- ⑤ High-pressure shut-off valve (HP)
- ⑥ Low-pressure shut-off valve (LP)
- ⑦ Level
- ⑧ Connector for piston-cylinder system
- ⑨ Reservoir with plug screw
- ⑩ Knurled nut
- ⑪ Thread adapter

CalibratorUnit model CPU6000

The models of the CPU6000 series are compact tools for use with a pressure balance (dead-weight tester). In particular when highly accurate measuring values, with measurement uncertainties of less than 0.025 %, are required, complicated mathematical calculations and corrections are necessary. With the CPU6000 in combination with the CPB-CAL (iPad® app) and/or WIKA-CAL (PC software) all critical ambient parameters can be registered and automatically corrected.

The CPU6000 series is made up of three instruments

Weather station, model CPU6000-W

The CPU6000-W provides measured values such as atmospheric pressure, relative humidity and the ambient temperature of the laboratory environment.

Pressure balance sensor box, model CPU6000-S

The CPU6000-S measures the piston temperature and displays the floating position of the masses.

Digital multimeter, model CPU6000-M

The CPU6000-M fulfils the function of a digital multimeter and power supply unit when electronic pressure transmitters must be calibrated.

Typical application

CPB-CAL iPad® app

The iPad® application calculates the masses for pressure balances (dead-weight testers) or the reference pressure while taking the measured parameters from the CPU6000 into account. The conversion can be carried out in all common pressure units. As an additional parameter, the local gravity can be given for location-independent measurements.

WIKA-CAL PC software - Weight calculator

With the demo version of the WIKA-CAL software and a CPB series pressure balance (dead-weight tester), the masses to be applied and the corresponding reference pressure can be determined. The pressure balance data (dead-weight tester data) can be entered into the database manually or imported automatically via an XML file available online. All ambient parameters and piston temperature can be entered manually into WIKA-CAL or can be measured automatically with the CPU6000 series, so that the highest accuracy can be achieved. WIKA-CAL demo version can be downloaded free of charge from the WIKA website.

Further specifications on the CPU6000 series can be found in data sheet CT 35.02.

For details of the WIKA-CAL calibration software see data sheet CT 95.10.



CPU6000 series and iPad® app CPB-CAL



Model CPU6000-W, CPU6000-S, CPB5800 and PC with WIKA-CAL software

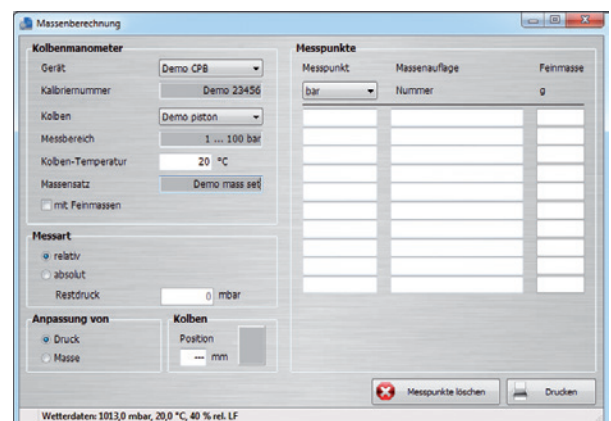

WIKA-CAL PC software - Weight calculator

Further pressure balances (dead-weight testers) within our calibration technology programme

Dead-weight tester in compact design, model CPB3800

Measuring ranges:

Hydraulic 1 ... 120 to 10 ... 1,200 bar
(10 ... 1,600 to 100 ... 16,000 psi)

Accuracy: 0.05 % of reading
0.025 % of reading (optional)

For specifications see data sheet CT 31.06



Dead-weight tester in compact design, model CPB3800

Pneumatic pressure balance, model CPB5000

Measuring ranges:

Pneumatic -0.03 ... -1 to +0.4 ... +100 bar
(-0.435 ... -14 to +5.8 ... +1,500 psi)

Accuracy: 0.015 % of reading
0.008 % of reading (optional)

For specifications see data sheet CT 31.01



Pneumatic pressure balance, model CPB5000

Hydraulic pressure balance, model CPB5800

Measuring ranges:

Hydraulic Single-piston measuring ranges:
1 ... 120 to 2 ... 300 bar
(10 ... 1,600 to 30 ... 4,000 psi)

Dual-piston measuring ranges:
1 ... 60 bar / 10 ... 700 bar to
1 ... 60 bar / 20 ... 1,400 bar
(10 ... 800 psi / 100 ... 10,000 psi to
10 ... 800 psi / 200 ... 20,000 psi)

Accuracy: 0.015 % of reading
up to 0.006 % of reading (optional)

For specifications see data sheet CT 31.11



Hydraulic pressure balance, model CPB5800

Pressure balance for differential pressure, model CPB5600DP

Measuring ranges (= static pressure + differential pressure):

Pneumatic 0.03 ... 2 to 0.4 ... 100 bar
(0.435 ... 30 to 5.8 ... 1,500 psi)

Hydraulic 0.2 ... 60 to 25 ... 1,600 bar
(2.9 ... 1,000 to 350 ... 23,200 psi)

Accuracy: 0.015 % of reading
0.008 % of reading (optional)

For specifications see data sheet CT 31.56



Pressure balance for differential pressure, model CPB5600DP

Set of fine increment masses M1 and F1

The masses included in the standard mass set are ideally suited for everyday use. If even smaller intermediate values need to be generated, using one of the class M1 or F1 set of fine increment masses with the following masses is recommended:

1 x 50 g, 2 x 20 g, 1 x 10 g, 1 x 5 g, 2 x 2 g, 1 x 1 g,
1 x 500 mg, 2 x 200 mg, 1 x 100 mg, 1 x 50 mg, 2 x 20 mg,
1 x 10 mg, 1 x 5 mg, 2 x 2 mg, 1 x 1 mg



Set of fine increment masses

Designation/Version	Order number
Set of fine increment masses (1 mg up to 50 g), class F1	7093874
Set of fine increment masses (1 mg up to 50 g), class M1	14025325
Adapter for test item connection with G ½ female thread, max. 1,600 bar, material 1.4571 stainless steel	11095912
Adapter for M30 x 2 male thread to M16 x 1.5 male thread for piston-cylinder connector block, operation as comparison test pump possible	11360071
Operating fluid for CPB5000HP up to max. 4,000 bar (60,000 psi), 1 litre	2099882
Operating fluid for CPB5000HP up to max. 5,000 bar (70,000 psi), 0.5 litres	11123150

Scope of delivery

- Base with dust protection cover
- Priming pump
- Spindle pump for filling, pressure generation and fine pressure adjustment
- Piston connection
- Test item connection with three thread adapters, M16 x 1.5, M20 x 1.5 and 9/16-18 UNF
- Piston-cylinder system
- Mass set divided between several transport cases, see specifications
- Masses, manufactured to local gravity (standard value: 9.80665 m/s²)
- VG22 mineral oil, 1.0 litre (up to 4,000 bar / 60,000 psi)
- Sebacate oil, 0.5 litres (for 5,000 bar / 70,000 psi)
- Flats 36 and flats 46 open-ended spanner
- Operating instructions in German and English language
- Factory calibration certificate

Options

- Systems with increased accuracy to 0.02 %
- Mass set manufactured to local gravity
- DKD/DAkkS calibration certificate

Ordering information

Model / Instrument version / Accuracy / Calibration for the pressure balance / Installation of CPU6000-S Calibrator Unit sensor system / Additional ordering information

© 11/2010 WIKA Alexander Wiegand SE & Co. KG, all rights reserved.
The specifications given in this document represent the state of engineering at the time of publishing.
We reserve the right to make modifications to the specifications and materials.