

EZ-Glider Linear Torque Arms Operation Instructions



EZ-Glider Linear Torque Arms Operation Instructions

Introduction

Prevents cross threading and side load. Keeps tool perpendicular.

Reduces RMI (Repetitive Motion Injury) and CTS (Carpal Tunnel Syndrome) while boosting production.

Extends in horizontal direction and arm length is adjustable.

Maneuvers smoothly as the arm absorbs torque reactions from electric & pneumatic screwdrivers.

Built with seasoned craftsmanship, every torque arm cylinder has four rows of ball bearings for smooth movement.

Provides tool suspension and balancing.

Includes an In-line Driver Clamp.

Max Torque

Model	Item #	lbf.ft	N.m	Clamp Dia.	Height	Min. Arm Reach	Max. Arm Reach	Balancer Capacity
EZ-12	260077	8.8	12	1 - 1 1/2"	32.5"	16 1/2"	22"	1.1 - 2.6 lbs
EZ-25	260078	18.4	25	1 - 2"	36.5"	16 1/3"	22"	2.2 - 4.8 lbs
EZ-40	260079	29.5	40	1 - 2"	40.5"	21 7/8"	29 1/2"	3.1 - 4.8 lbs
EZ-100	260080	73.7	100	1 - 2"	40.5"	25 1/3"	33"	4.4 -7.7 lbs

Note: An additional balancer (Item #260152) can be added to the EZ-40 & EZ-100 model to increase balancer capacity. The additional balancer increases the dual balancer capacity to 5.3 - 8.8 for the EZ-40, and 6.6 - 13.2 for the EZ-100.

Mounting

1. Place the Foot (base) on a perfectly horizontal working surface and bolt it down (screws not included).
2. Make sure the Arm can move freely without obstruction or danger for the operators.

Model	Diameter E (mm)	Diameter D (mm)	Diameter F (mm)
EZ-12	65	8.5	78
EZ-25	65	8.5	78
EZ-40	100	8.5	118
EZ-100	126	10.5	148

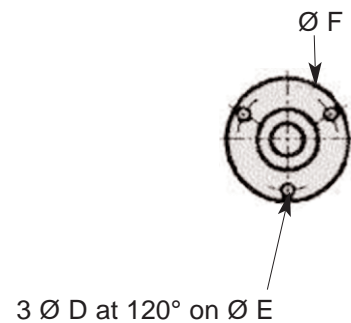

EZ-Glider Linear Torque Arms Operation Instructions

Installation

1. After mounting the Foot and Pole, slide the "Red Cylinder Base" onto the Pole. The Eye Hook should be located topside.
2. There are attachment holes on the Red Cylinder Base. Align the Arm on the Red Cylinder Base. There are multiple Mounting Holes on the Arm. Attach Arm at desired working distance.
3. The Balancer should be attached to Top Bracket. Place Top Bracket on the top of the Pole. The Balancer should be aligned with the Eye Hook on the Red Cylinder Base.
4. Attach Balancer cable to the Eye Hook.

Tool Clamp

The Tool Clamp is mounted on the chrome Slides using two CHC screws (Torque 6 N.m). Before mounting a tool in the Tool Clamp, make sure the Tool Clamp is securely screwed onto the chrome Slides to prevent the unintentional disengagement of the tool, which could injure the operator.

Clamping a Tool in the Tool Clamp

1. Unscrew the two screws at the front end of the Tool Clamp using a suitable hexagonal head key.
2. Position tool in the Tool Clamp by clamping the lower section of the tool.
3. Moderately tighten the two screws until the tool is completely clamped.

Note: Excessive clamping can alter the function of the tool mounted on the arm.

Insufficient clamping will reduce or prevent the arm from operating properly.

Adjusting the Balancing System

The effective load at the end of the arm determines the strain of the balancing system. The load is correctly balanced when the operator can handle the tool effortlessly.

A decrease in strain is obtained by turning the balancing system's thumb wheel clockwise.

An increase in strain is obtained by turning the balancing system's thumb wheel counterclockwise. Please refer to the instructions on the body of the balancing system.

The cable travel must be adjusted properly using the rubber ball.

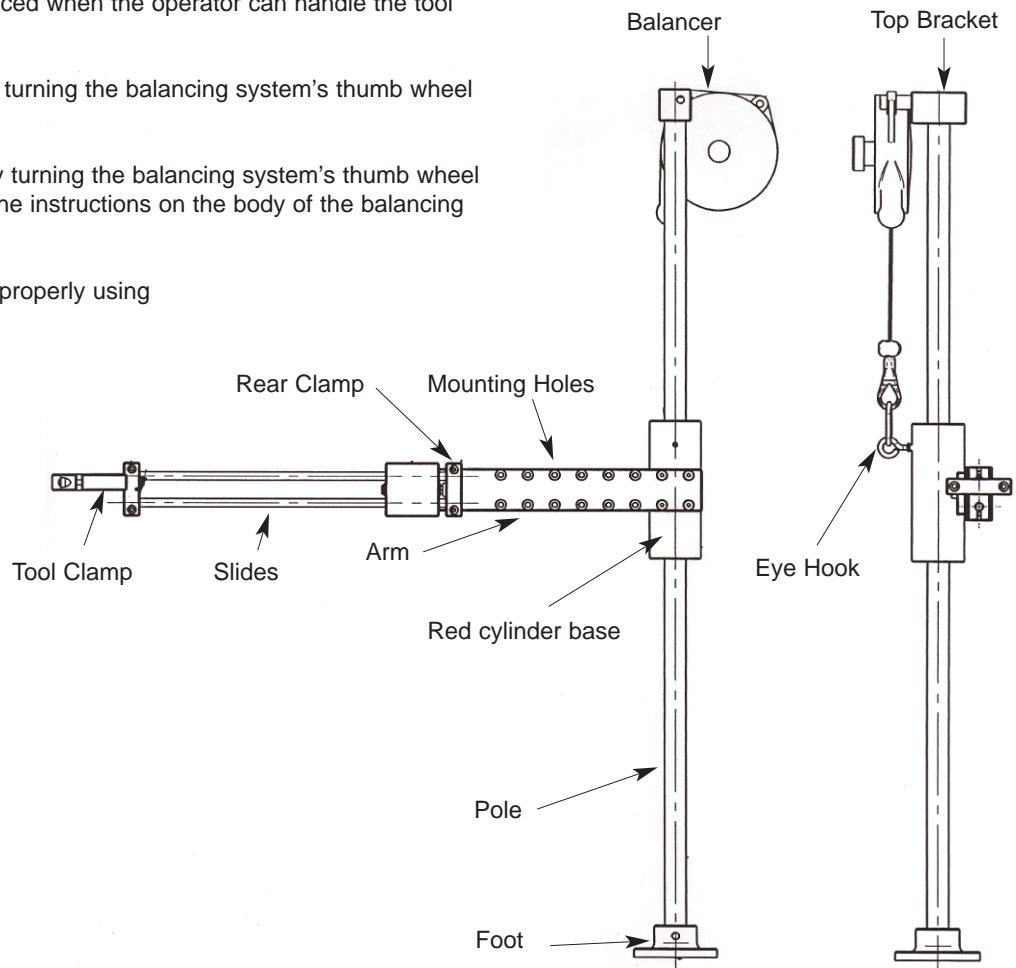

EZ-Glider Linear Torque Arms Operation Instructions

Recommendations

1. Make sure the torque arm is never used above the torque values that it is designed for.
2. Never use the torque arm with effective loads at the arm end which exceed the manufacturer's recommendations.
3. The torque arms are designed for a working cycle of about 300,000 fastening operations without maintenance.
4. The torque arm's total travel (reach) must be taken into account before planning the workstation layout.
5. Make sure the torque arm's foot (base) is correctly attached and the work surface is stable.

Maintenance

If the axes becomes difficult to slide:

1. Dismantle the Arm and chrome Slides. Dismantle the Red Cylinder Base.
2. Use a compressed air gun to clean the linear bearings.
3. Wipe the Sliding Bush and chrome Slides with a dry cloth.
4. Re-assemble the Torque Arm and check that the chrome Slides are correctly aligned and the tool is properly tightened.

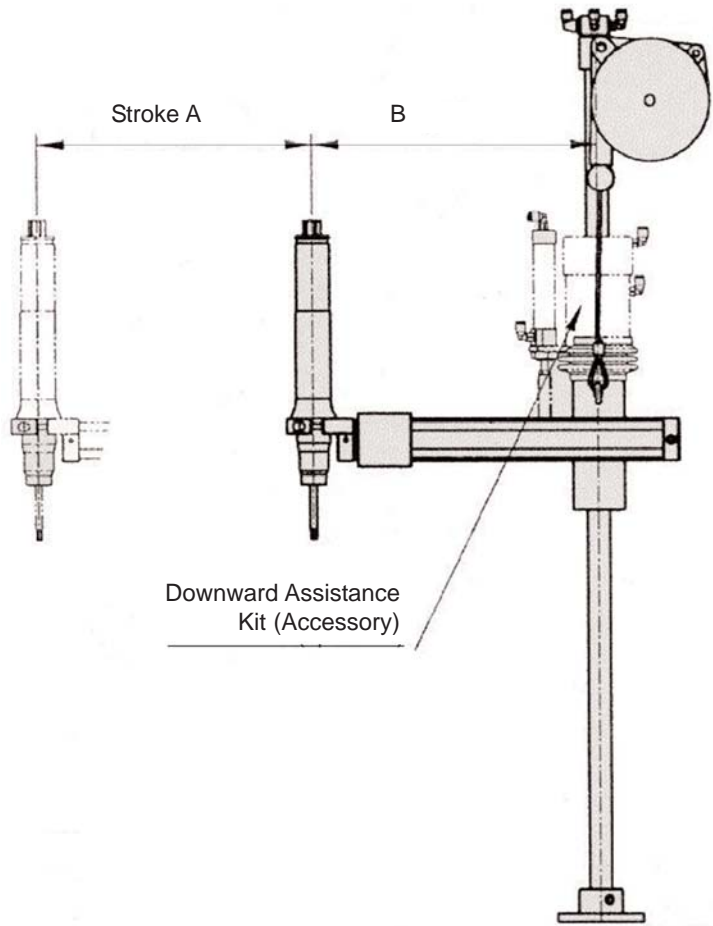

Overall Dimensions

Model	A	B	Height
EZ-12	9"	7.5 - 13"	32.5"
EZ-25	8"	8 - 14"	36.5"
EZ-40	11.5"	10 - 18"	40.5"
EZ-100	13"	12.4 - 20"	40.5"

EZ-Glider Linear Torque Arms Operation Instructions

Accessories

Anti-Rotating Clamp

Attach an “Anti-Rotating Clamp” to prevent the arm from rotating side-to-side to help the operator target the screw quickly and precisely.

1. Detach the Balancer Cable from the Eye Hook. Remove the balancing system from the Pole.
2. Remove the Red Cylinder Base and Arm from the pole.
3. Put the Anti-Rotation Clamp onto the Pole. Attach the Red Cylinder Base and Arm on the pole.
4. Screw the Anti-Rotation device onto the rear part of the Arm (Mounting Holes).
5. Tighten the screws on the top and bottom (red bases) part of the Anti-Rotating Clamp to the Pole.
5. Reassemble the Balancing System to the Pole. Attach Balancer Cable to the Eye Hook.



ARP System

ARP (automatic rest position): A recoil spring positioned on the Slide to permit the arm to come back to the rest position as soon as you release it.

1. Loosen and remove the Rear Clamp from the Slides.
2. Disengage the Slides and Tool Clamp.
3. Insert the Spring and the Stopper of the ARP system.
4. Reassemble the Slides and Tool Clamp.
5. Firmly tighten the Rear Clamp, making sure that the slides are correctly aligned.

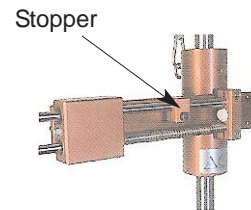

Extension Slides

Expands the Maximum Arm Reach of the EZ-Glider Linear Arms.

1. Loosen and remove the Rear Clamp from the Slides.
2. Disengage the Slides and loosen the Tool Clamp.
3. Tighten the Tool Clamp onto the Extension Slides.
4. Reassemble the Slides and Tool Clamp.
5. Firmly tighten the Rear Clamp, making sure that the slides are correctly aligned.

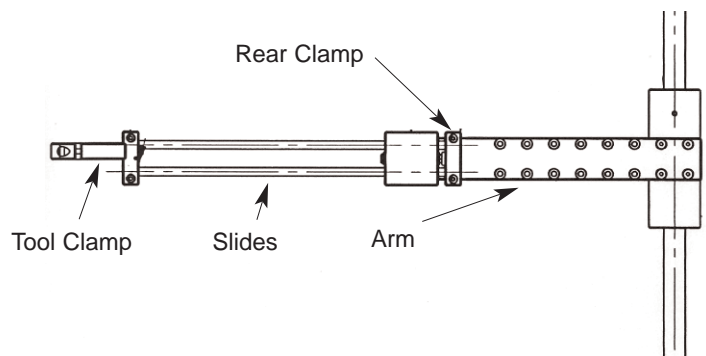

Extension Slides

EZ-Glider Linear Torque Arms Operation Instructions

Accessories

Extension Double Slides

Expands the Maximum Arm Reach of the EZ-Glider Linear Arms by adding a second slide to the arm.

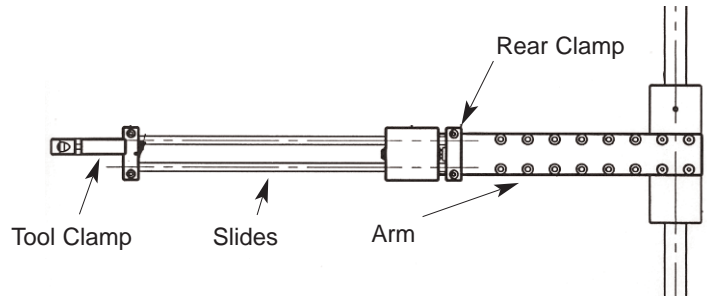
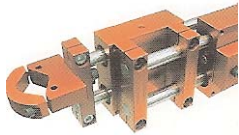

1. Remove Rear Clamp
2. Remove the original Slides
3. Remove the Rear Clamp
4. Position the Double Slide inside the two holes.
5. Attach the Rear Clamp back on.
6. Position the original Slides into the two holes of the "Double Slide"
7. Attach the Rear Clamp back on.