

REED

Model VC05

Loop Calibrator

Instruction Manual



[www reed instruments com](http://www.reed instruments.com)

Table of Contents

Safety	
Features.....	
Specifications	
Instrument Description	
Operating Instructions.....	
<i>ON/OFF</i>	
<i>Outputs</i>	
<i>Automatic Power Off</i>	
<i>Calibration</i>	
Battery Replacement.....	

For service (repairs or calibration) on this or any other REED product or information on other REED products, contact REED Instruments at info@reedinstruments.com.

Safety Information

To ensure safe usage, the following signs are used only as specified in this instruction manual.

⚠ WARNING Indicates that the current operation does not comply with correct instruction, therefore causing potential hazards to the user or instrument. This also indicates how to avoid such hazards.

! CAUTION Indicates that the current operation does not comply with correct instructions, therefore causing potential hazards to the instrument. Also indicates how to avoid incorrect operation.

NOTE Serves as a sign to remind the user that they must understand the correct operation before proceeding.

To prevent the user and the instrument from electric shock and other hazards, it is necessary to follow the following regulations:

Warning - **⚠ WARNING**

- Do not operate the instrument in the presence of flammable gas, explosive gas or vapor. This is extremely dangerous.
- Never apply more than 30V between any two terminals, or between terminal and ground.

Caution - **! CAUTION**

- The split case (top and bottom) is not to be removed, unless by qualified technicians.
- To clean the instrument, periodically wipe the case with a damp cloth and mild detergent, do not use any corrosive solvents.

Note - **NOTE**

- For optimal accuracy, allow the instrument to warm up for 5 minutes before operating.
- If the automatic reference-junction temperature compensation of the instrument deviates from its designed accuracy, on this or any other REED product, contact REED Instruments at info@reedinstruments.com.

Features

- mA sourcing, simulation and measurement
- 0-28 VDC measurement to check loop voltage
- 0.02% accuracy and 0.001% of span display
- Simulate mA and % of span display
- Selectable step or ramp outputs
- 24V loop power supply

Specifications

Power supply: 9V battery (ANSI/NEDA 1604A or IEC 6LR619V alkaline)

Battery life: About 20 hours under the condition of 10mA

Size: 200×100×40mm (with holster)

Weight: 550g (with holster)

Includes: Set of CF-36 industrial test leads (alligator clips attached to probes), protective holster, carrying case, and battery

Output Functions

Applicable range from 18 to 28°C, within one year of calibration.

Output	Range	Output Range	Resolution	Accuracy	Note
Current	20mA	0.000 to 22.000mA	0.001mA	±0.05% of set value ±4µA	Max 1KΩ at 20mA, see Note 1
Simu. transmitter (absorp. current)	-20mA	0.000 to -22.000mA	0.001mA		Max 1KΩ at 20mA, see Note 2
Loop power	24V	-	-	±10%	Max output current up to 25mA

Input Functions

Applicable range from 18 to 28°C, within one year of calibration.

Input	Range	Input Range	Resolution	Accuracy	Note
Voltage	28V	-0.200 to 28.000V	1mV	±0.02% of reading ±2mV	Input resistance 2MΩ
Current	20mA	-1.000 to 22.000mA	0.001mA	±0.02% of reading ±4μA	Max 1KΩ at 20mA, see Note 2
Loop power	20mA	0.000 to 22.000mA			Providing 24V loop power

Note 1: When the battery voltage exceeds 6.8V, the max. load is 1KΩ at 20mA. When its voltage lies between 5.8V and 6.8V, the max load is 700Ω at 20mA.

Note 2: Power supply range: 5 to 25VDC.

Note 3: Temperature coefficient: ±0.005% of the range per °C for the temperature ranges 5°C to 18°C and 28°C to 40°C.

For service on this or any other REED product or information on other REED products, contact REED Instruments at info@reedinstruments.com

Instrument Description

1. LCD screen
2. Power button
3. Single step/auto switch button
4. 25% single step setting/auto ramp button
5. 0% & 100% of setting/auto ramp start button
6. Output/input on-off button
7. Unit mA%/V select button
8. ◀▶ output digit selection button
9. ▲▼ output value setting button
10. Input/output terminals

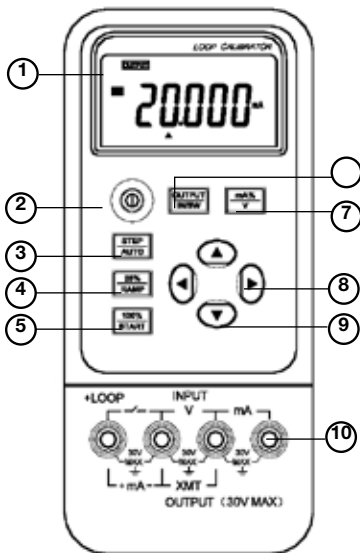

Display Description

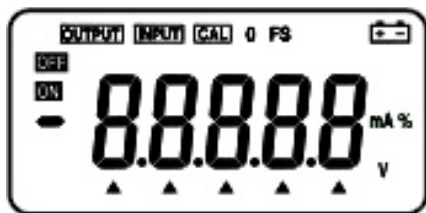

	Indicates that the instrument is in an output state
	Indicates that the instrument is in a input state
	Indicates that the instrument is in a calibration state
	Indicates that the instrument is in a calibration state, denoting that the zero point or the full scale point is now in calibration
	Indicates that the battery power is low and needs to be replaced
	Indicates that the output digits need to be set
V. mA. %	Indicates the current output value (unit of measure)
	Indicates that the output signal is on or off

Operating Instructions

Power ON/OFF

Press the Power button to turn the instrument on. Press this button again, holding for one second to turn the instrument off. When the instrument is on, it will begin an internal self-diagnosis at which time the full screen will be displayed. Once complete, the instrument is ready to be used.

Automatic power-off

As a default the instrument will be set to automatically turn itself off after 10 minutes without any action. Follow the steps below to turn the Auto-Power Off function off.

1. Be sure the meter is powered off.
2. Press both the POWER and mA%/V buttons simultaneously. The display will indicate the symbol 'AP-XX'.
3. Press the ▼ button to activate or deactivate the Auto-Power Off function. 'AP-OFF' indicates that there is no automatic power-off function set, and 'AP-ON' indicates the automatic power-off function is activated.
4. Turn the meter off to save the setting.

Outputs

The output terminal of the instrument can produce DC voltages set by the user or simulating resistance.

! CAUTION Do not apply any voltage to the output terminal during the operation. If any improper voltage is applied to the output terminal, it will cause damage to the internal circuits.

Output Operation Procedure

Function Operation	Range Operation	Display	Set Range
DCA 20 mA	20 mA or %	00.000 mA or -025.00 mA %	00.000 to 22.000 mA or -025.00 to 112.50 mA %

Current Output

1. Insert one end of the test leads into the +mA output jack and connect the other end to the input of the meter, as shown in the diagram below.

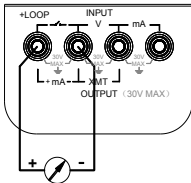

2. Press the OUTPUT/IN/SW button and **OUTPUT** will appear on the display indicating that the calibrator is in an output state.
3. Press the mA%/V button to select the output to be either mA or %, in which 0% indicates 4mA and 100% indicates 20mA.
4. Press the ◀ ▶ buttons to select the output digits.
5. Press the ▲ ▼ button to change the numerical value of the set digits. Hold the button and the value will keep varying.

25% Step Current Output

1. Connect the test leads to the meter as stated in the Current Output procedures.
2. When the OUTPUT/IN/SW button is pressed, **OUTPUT** will appear in the display it indicating the calibrator is in an output state.
3. Press the 25%/RAMP button and **25%** will appear on the LCD.
4. Press the mA%/V button to select the set output to mA or %
5. Press the ▲ ▼ button to change the output in a value of 25%, in which 0% indicates 4mA and 100% indicates 20mA.
6. Press the 25%/RAMP button again to exit.

Current Output Set for Zero Point & Full Scale

1. Connect the test leads to the meter as stated in the Current Output procedures.
2. Press the OUTPUT/IN/SW button and **OUTPUT** will appear on the display indicating that the calibrator is in an output state.
3. Press the 100%/START button and the symbols '0' and 'FS' will appear in the display.
4. Press the ▲ button to set to 100% (full scale) and the current output will be 20mA. Press the ▼ button to be set to 0% (zero point) and the current output will be 4mA.
5. Press the 100%/START button again to exit.

Auto-Ramp

1. Connect the test leads to the meter as stated in the Current Output procedures.
2. Press the OUTPUT/IN/SW button and **OUTPUT** will appear on the display indicating that the calibrator is in an output state.
3. Press the STEP/AUTO button and the symbols **OUTPUT**, 'OFF', 'L' and '4mA' will appear on the display indicating that the calibrator is entering RAMP mode.
4. Press the 25%/RAMP button again to change the type of the output ramp from 'L', 'H', and 'r'. 'L' indicates a low speed ramp, which is set to a cycle of 60 seconds. 'H' indicates a high speed ramp, which is set to a cycle of 30 seconds. 'r' indicates auto-stair step ramp, which pauses 5 seconds at each step.
5. Press the 100%/START button to start output on the selected output ramp. 'ON' will appear on the LCD indicating that the output is activated. Press the 100%/START button again and the output will pause on the current value. 'OFF' will appear on the LCD indicating that the output is deactivated. Press the 100%/START button again to resume output at the set ramp from the pause value. When the 'OFF' symbol appears, press any one of the ◀▶▲▼ buttons to bring the output back to 0% and 4mA.

Simulating Transmitter Output (XMT)

1. Insert one end of the test lead to the 'XMT' output jack of the calibrator and connect the other end with the input terminal of the user's instrument as shown in the following diagram:

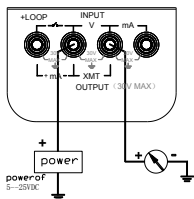

2. The button-operation is the same as that as indicated in the Current Output section

NOTE

- Power supply range: 5 to 25VDC
- During an output operation, use a external 24V DC power supply in order to prolong battery life.

Calibrator Measurement

⚠ WARNING

- Never apply more than 30V between any two terminals, or between any terminal and the ground. Any voltage more than 30V could result in damage to the calibrator, as well as personal injury.

! CAUTION

- During operation, do not apply a voltage or current exceeding the measuring range to the input terminal. This could cause damage to the calibrator.
- During the operation, turn off the instrument before connecting the calibrator. Connecting to the Calibrator without it being shut it down may cause damage.

Measuring DC Current

1. Insert one end of the test lead into the mA input terminal and connect the other end to the output of the user's instrument as shown in the following diagram:

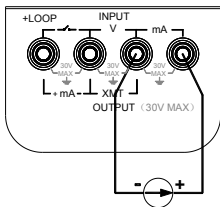

2. Press the OUTPUT/IN/SW button when **INPUT** appears on the display. It indicates that the calibrator is in an input state.
3. Press the mA%/V button to select mA or %. The value of 0% indicates 4mA and the value of 100% indicates 20mA.
4. The unit refreshes twice per second. If the measured value exceeds the measuring range, the display will indicate the symbol '-OL-' (overload).

Measuring DC Voltage

1. Insert one end of the test lead into the V input jack of the calibrator and connect the other end with the output of the user's instrument as show in the following diagram:

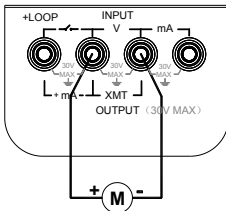

2. Press the OUTPUT/IN/SW button and **INPUT** will appear on the display, indicating that the calibrator is in an input state.
3. Press the mA%/V button to select the V function, indicated by 'V' appearing on the LCD.
4. The unit refreshes twice per second. If the measured value exceeds the measuring range, the display will indicate the symbol '-OL-' (overload).

Providing 24V Power Supply for Measuring Loop Current

1. Insert the test lead into the +LOOP & mA input jacks of the calibrator as shown in the following diagram:

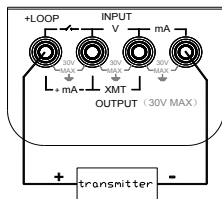

2. The operations are the same as described in the Measuring DC Current instructions.

Measuring Switching Contact Status

1. Insert one end of the test lead into the switching contact measuring jack of the calibrator and connect the other end to the switching contact of the user's instrument as shown in the following diagram:

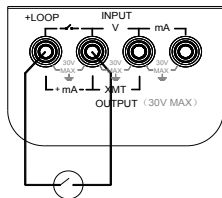

2. Press the OUTPUT/IN/SW button. The **INPUT** symbol will appear followed by the word 'CLOSE' or 'OPEN' according to the measured switching contact status. When the switching resistance exceeds 15K Ω , the contact is regarded as at an 'Off' state.

Calibration

It is recommended that you calibrate the unit once per year in order to keep correct accuracies. Contact REED Instruments for assistance regarding calibration, repairs, warranty, trouble-shooting, and more at: service@reedinstruments.com.

Battery Replacement

When the  appears on the LCD, the batteries need to be replaced. Follow the instructions below to properly replace the batteries.

1. Turn the power off the meter and remove any test leads that may be attached to the meter.
2. Remove the holster from the calibrator by releasing the lock in the indicated direction.
3. Replace the old battery with a new 9V battery. Be sure to check polarities. Do not mix old batteries with new batteries.
4. Put the battery cover back on and lock it in the indicated direction. Put the holster back on the calibrator.

