

HIOKI

INSTRUCTION MANUAL

3154

DIGITAL Mohm HiTESTER

HIOKI E. E. CORPORATION

Contents

Introduction	i
Inspection	i
Safety Notes	ii
Notes on Use	vi
Chapter 1 Outline	1
1.1 Product Introduction	1
1.2 Features	1
1.3 Controls and Functions	3
1.3.1 Displays	3
1.3.2 Front Panel	4
1.3.3 Rear Panel	5
Chapter 2 Preparation for Testing	7
2.1 Connecting Power Cord	8
2.2 Powering On and Off the Unit	9
2.3 Connecting Measurement Probes	10
2.4 Using Handle	11
2.5 Connecting to Equipment to be tested	12
Chapter 3 Setting Basic Testing Conditions	13
3.1 Setting Test voltage	14
3.2 Setting and Verifying Comparator	15
3.2.1 Setting Lower Limit Value	15
3.2.2 Setting and Verifying Test mode	17
3.3 Setting and Verifying Resistance Range	18
3.4 Setting and Verifying Timer	19
3.4.1 Setting and Verifying Test Duration	19
3.4.2 Setting and Verifying Delay Time	20
3.4.3 Determining Delay Time	22
3.5 Setting Sampling Rate	24
3.6 Example Test Condition Setting	25

Chapter 4	Testing	27
4.1	Test Flow	28
4.2	Start Testing	29
4.3	During Testing (TEST status)	30
4.4	Measurement Value Display	31
4.5	Completing Testing	32
4.6	Automatic Discharge	33
4.7	Testing with 9299 SWITCHED PROBE	34
4.7.1	Connecting 9299 SWITCHED PROBE	35
4.7.2	Setting 9299 SWITCHED PROBE	36
Chapter 5	Other Functions	37
5.1	Setting and Verifying Beep Sound	38
5.1.1	Setting Judgment Beep Sound	38
5.1.2	Setting Beep Sound During Key Press	39
5.2	Saving and Loading Test Conditions	40
5.2.1	Saving Test Conditions	40
5.2.2	Loading Test Conditions	42
5.3	Key Lock Function	43
5.4	System Reset	44
Chapter 6	External Interface	45
6.1	Controlling 3154 with External I/O	45
6.1.1	Terminal Connector Board/Signal Wires	46
6.1.2	Electric Specifications	48
6.1.3	Connecting External I/O Terminal	50
6.1.4	External I/O Terminal Circuit	52
6.1.5	Setting TEST Signal OFF Timing	54
6.1.6	Timing Chart	56
6.1.7	Output Signal Connection Example	58
6.2	Analog Outputting	59
6.3	Outputting to Printer	60
6.3.1	Connecting Printer	64
6.3.2	Printing Example	65

Chapter 7 RS-232C Interface	67
7.1 Controlling from Personal Computer	68
7.1.1 Preparing for Data Transfer	69
7.1.2 Communication	71
7.1.3 Command Format	72
7.1.4 Numeric Format Chart	76
7.1.5 Command Reference	77
7.2 Sending Measurement Data to PC	89
Chapter 8 Specifications	93
8.1 General Specifications	93
8.2 Measurement Part Specifications	95
8.3 Dimensions	101
8.4 Options and specifications	102
Chapter 9 Maintenance and Service	105
9.1 Maintenance and Inspection	105
9.2 Trouble shooting	107

Introduction

Thank you for purchasing this HIOKI "3154 DIGITAL MΩ HiTESTER." To get the maximum performance from the unit, please read this manual first, and keep this at hand.

Inspection

When the unit is delivered, check and make sure that it has not been damaged in transit. In particular, check the accessories, panel switches, and connectors. If the unit is damaged, or fails to operate according to the specifications, contact your dealer or HIOKI representative.

Accessories

Verify that following standard accessories are complete.

Instruction Manual	1
Grounded three-core power cord	1

NOTE

9185 TEST LEAD and 9294 TEST PROBE are not included.
Please purchase separately according to your needs.

Shipment of the unit

If reshipping the unit, preferably use the original packing.

Warranty

HIOKI cannot be responsible for losses caused either directly or indirectly by the use of the 3154 with other equipment, or if ownership is transferred to a third party.

Safety Notes



This equipment is designed according to IEC 61010 Safety Standards, and has been tested for safety prior to shipment. Incorrect measurement procedures could result in injury or death, as well as damage to the equipment. Please read this manual carefully and be sure that you understand its contents before using the equipment. The manufacturer disclaims all responsibility for any accident or injury except that resulting due to defect in its product.

This Instruction Manual provides information and warnings essential for operating this equipment in a safe manner and for maintaining it in safe operating condition. Before using this equipment, be sure to carefully read the following safety notes.

Safety Symbols



- This symbol is affixed to locations on the equipment where the operator should consult corresponding topics in this manual (which are also marked with the  symbol) before using relevant functions of the equipment.
- In the manual, this mark indicates explanations which it is particularly important that the user read before using the equipment.



Indicates the ON side of the power switch.



Indicates the OFF side of the power switch.



Indicates that this terminal carries voltage at dangerous levels.







Indicates AC (Alternating Current).



Indicates DC (Direct Current).

The following symbols are used in this Instruction Manual to indicate the relative importance of cautions and warnings.

 DANGER	Indicates that incorrect operation presents extreme danger of accident resulting in death or serious injury to the user.
 WARNING	Indicates that incorrect operation presents significant danger of accident resulting in death or serious injury to the user.
 CAUTION	Indicates that incorrect operation presents possibility of injury to the user or damage to the equipment.
 NOTE	Denotes items of advice related to performance of the equipment or to its correct operation.

Overvoltage Categories

To ensure safe use of measurement, IEC 60664 establishes safety level standards for different locations, classified as CAT I through CAT IV, and called overvoltage categories. These are defined as follows.

CAT I	Secondary electrical circuits that are connected to a wall outlet through a transformer or similar device.
CAT II	Primary electrical circuits in equipment connected to a wall outlet via a power cord (portable tools, household appliances, etc.)
CAT III	Primary electrical circuits of heavy equipment (fixed installations) connected directly to the distribution panel, and feeders between the distribution panel and outlets.
CAT IV	The circuit from the service drop to the service entrance, then to the power meter and to the primary overcurrent protection device.

Higher-numbered categories correspond to electrical environments with greater momentary energy, so a measurement device designed for CAT III environments can endure greater momentary energy than a device designed for CAT II. Use of a lower category product in a higher category environment could result in a severe accident and must be carefully avoided.

Measurement terminal of the unit is applicable to CAT I, and power supply to CAT II.

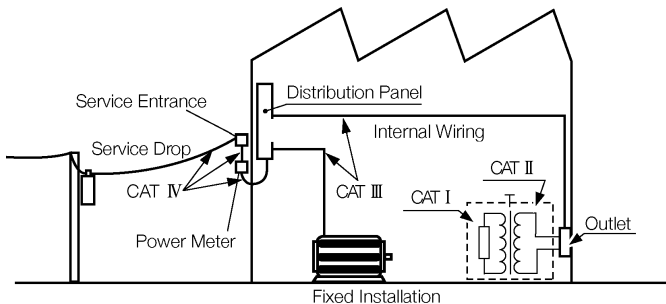

Accuracy

The specifications in this manual include figures for "measurement accuracy" when referring to digital measuring instruments, and for "measurement tolerance" when referring to analog instruments.

-
- f.s. (maximum display or scale value, or length of scale)
Signifies the maximum display (scale) value or the length of the scale (in cases where the scale consists of unequal increments or where the maximum value cannot be defined).
In general, this is the range value (the value written on the range selector or equivalent) currently in use.
- rdg. (displayed or indicated value)
This signifies the value actually being measured, i.e., the value that is currently indicated or displayed by the measuring instrument.
- dgt. (resolution)
Signifies the smallest display unit on a digital measuring instrument, i.e., the value displayed when the last digit on the digital display is "1".
-

Notes on Use

In order to ensure safe operation and to obtain maximum performance from the unit, observe the cautions listed below.



- **The unit contains high-voltage components. To ensure safety, never remove the cover panel.**
- **Before using the unit, make sure that the sheathing on the probe is not damaged and that no bare wire is exposed. If there is damage, using the unit could cause electric shock. Contact your dealer or HIOKI representative.**
- **Do not use the unit where it may be exposed to corrosive or explosive gases. The unit may be damaged, or explosion may occur.**



To prevent electric shock, do not allow the unit to become wet and do not use the unit when your hands are wet.

CAUTION

- The unit should always be operated indoors in a range from 0°C to 40°C and 80% rh or less. Do not use the unit in direct sunlight, dusty conditions, or in the presence of corrosive gases.
 - Do not store or use the unit where it will be exposed to direct sunlight, high temperatures, high humidity, or condensation. If exposed to such conditions, the unit may be damaged, the insulation may deteriorate, and the unit may no longer satisfy its specifications.
 - Do not use the unit near any device which generates strong electromagnetic radiation or near a static electrical charge, as these may cause errors.
 - To avoid damage to the unit, do not subject the equipment to vibrations or shocks during transport or handling. Be especially careful to avoid dropping the equipment.
 - In order to avoid the risk of electric shock and to prevent equipment damage, turn power OFF on equipment before handling interface connectors. Be sure to connect properly to avoid short-circuit.
 - Because external I/O INT.GND terminal, RS-232C connector frame, ground terminal and analog output GND terminal are grounded, all equipment connected with GND terminals are grounded. Use caution when handling.
-

Chapter 1

Outline

1.1 Product Introduction

HIOKI 3154 DIGITAL M Ω HiTESTER performs insulation resistance testing on components and equipment using direct current voltage. Comparator and timer functions facilitate easy and accurate insulation resistance testing. Equipped with six selectable test voltages and external I/O, RS-232C interface and analog output terminal, HIOKI 3154 DIGITAL M Ω HiTESTER proves its efficiency and versatility from laboratory to production and inspection line testing.

1.2 Features

- (1) Easy Testing in accordance with safety standards
Select from six test voltages from 25 V to 1000 V.
Pass/Fail judgment function comparing measured value by setting lower limit value and timer function support wide variety of insulation resistance testing according to safety standards.
- (2) Easy-to-read display
High definition LED display

- (3) Saves Setting Conditions
Saves up to ten testing conditions including lower limit value to quickly change conditions for various standards.
Also restarts with values saved at power shutdown when power is turned on.

- (4) External Interface
External I/O outputs signals according to 3154 status and inputs start/stop signals. Selectable from various test voltage and comparator combinations. Records extended insulation resistance fluctuations using analog output.

- (5) Equipped with RS-232C Interface
Use personal computer for automated testing and recording test results. Optional 9442 PRINTER provides measurement data printing.

- (6) Optional Push Switch Probe
9299 SWITCHED PROBE enables efficient manual testing.

- (7) Automatic Discharge Function
Automatically discharges any charge buildup in measured object after testing.
TEST lamp blinking during discharge indicates discharge status.
Protects equipment from possible damage during successive insulation resistance testing.

1.3 Controls and Functions

1.3.1 Displays

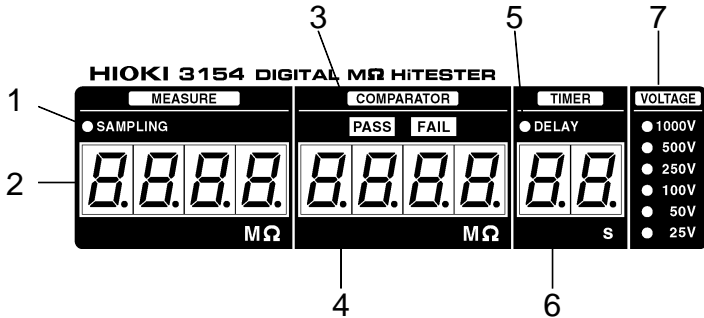

1. Sampling lamp	Blinks during resistance measurement.
2. Measurement value display	Displays measured resistance value.
3. Judgment result display lamp	Displays comparator PASS/FAIL results.
4. Lower limit display	Displays comparator lower limit value.
5. DELAY lamp (Delay time setting lamp)	On when delay time is set.
6. Timer display	Displays test duration or delay time.
7. Test voltage display	Displays test voltage.

1.3.2 Front Panel

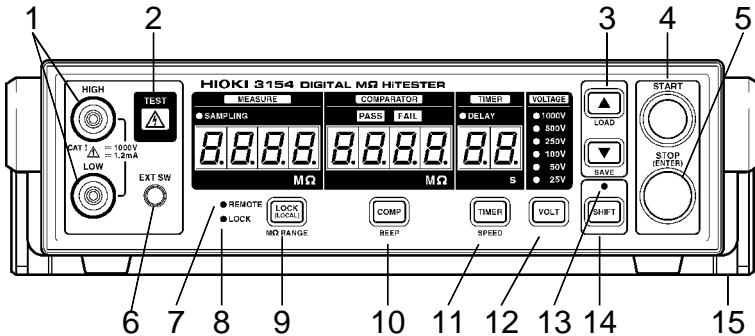

1. Measurement terminals	Connect measurement probes. High voltage occurs between terminals continuously electrically connected to rear panel measurement terminals.
2. TEST lamp	Turns on during testing. Blinks during discharging buildup in tested object.
3. ▲/▼ key LOAD/SAVE key	Press to change settings. Press SHIFT key - LOAD/SAVE key to save and load setting conditions.
4. START key	Press to start testing.
5. STOP key	Press to terminate testing or to confirm settings.
6. EXT.SW terminal	Switch signal terminal for optional 9299 SWITCHED PROBE.
7. REMOTE lamp	Turns on when communicating with personal computer via RS-232C.
8. LOCK lamp	Turns on when key lock is engaged.
9. LOCK key MΩ RANGE key	Press to engage or disengage key lock. Press SHIFT key - MΩ RANGE key to change to and from auto range/manual range.
10. COMP key BEEP key	Press to set comparator. Press SHIFT key - BEEP key to set beep sound.
11. TIMER key SPEED key	Press to set test duration and delay time. Press SHIFT key - SPEED key to set measurement speed.

12. VOLT key	PRESS to set test voltage.
13. SHIFT lamp	Turns on when SHIFT key is pressed.
14. SHIFT key	Press to engage shift. When SHIFT key is pressed, shift is engaged and SHIFT lamp turns on. Press again to disengage shift. When shift is engaged, functions displayed in blue below keys become valid.
15. Handle/Stand	Adjust handle to use as a stand.

1.3.3 Rear Panel

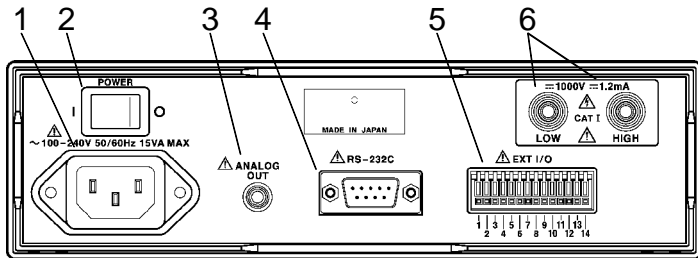

1. Power supply connector	Terminal to connect power cord. (Internal fuse type)
2. POWER switch	Turns power ON/OFF.
3. Analog output terminal	Converts measured resistance value and outputs voltage. Use to connect 9094 OUTPUT CORD.
4. RS-232C terminal	Use to connect RS-232C for remote operation or optional 9442 PRINTER.
5. External I/O terminals	Outputs 3154 status and inputs start/stop and test voltage switching signals.
6. Rear measurement terminals	Connect measurement probes. High voltage occurs between terminals. Continuously electrically connected to front panel measurement terminals.

Chapter 2

Preparation for Testing

Before testing preparation, read each note carefully.

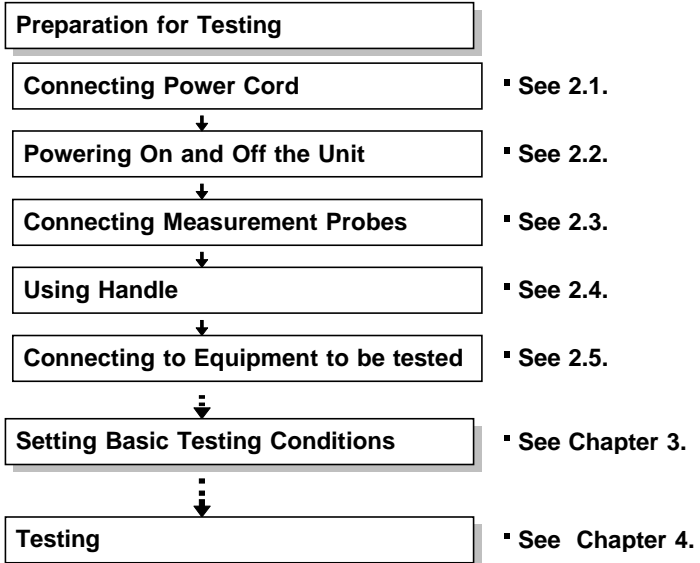
**NOTE**

See 4.7 Testing with SWITCHED PROBE to conduct measurement using 9299 SWITCHED PROBE.

2.1 Connecting Power Cord



- The unit is constructed so as to be connected to a ground line via a three-core power cord that is supplied with the unit.
- In order to avoid electric shock, connect the unit to a properly grounded (3-pin) outlet using the power cord provided.
- Before turning on the power, make sure that the voltage of the power supply being used matches the supply voltage indicated on the rear panel of the unit.
- If an attempt is made to use an improper supply voltage, there is danger of damage to this unit and of life-threatening risk to the operator.
- When unplugging the power cord from the power receptacle or from the unit, grasp the plug, not the cord, in order to avoid damaging the cable.

■ Connecting Power Cord

- (1) Verify that the 3154 POWER switch is OFF (O).
- (2) Connect power cord supplied with the 3154 to power supply connector located in the back.
- (3) Connect power cord plug to grounded dual polarity power outlet.

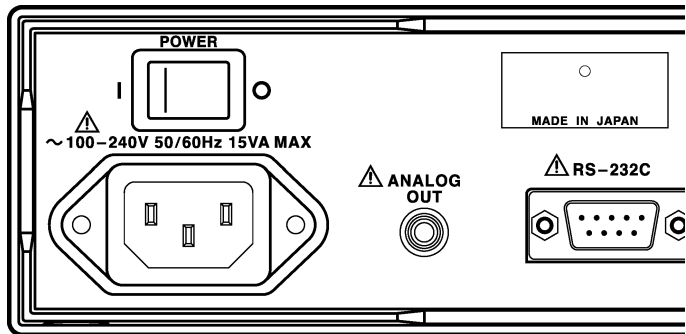

2.2 Powering On and Off the Unit

■ Powering On

- (1) Turn POWER switch ON (I) on the rear panel.
- (2) All displays light up displaying product name and software version.
- (3) Returns to normal READY status for use with settings saved prior to turning power off.

For stable measurement readings, allow thirty minutes or more to warm up after turning power on.

■ Powering Off

Turn POWER switch OFF (O) on the rear panel. Settings are saved when turning power off.

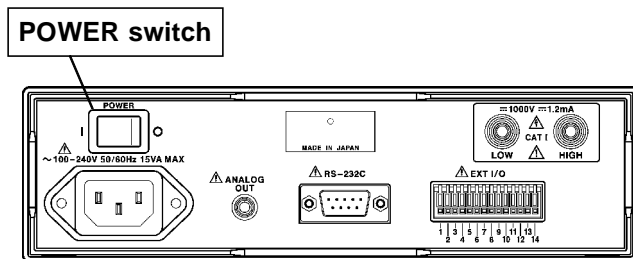

2.3 Connecting Measurement Probes



- To avoid the risk of electric shock, be sure to press the 3154 STOP key and confirm that the TEST lamp is off before connecting/disconnecting probes. Do not keep power on equipment to be tested when connecting probes.
- Before connecting probes, confirm that no insulation is ripped exposing any metal on probes.



- For safety reasons, only use the 9185 TEST LEAD or 9294 TEST PROBE provided with the unit for measurement.
- To avoid damaging probes, do not bend or pull the probes.

Although measurement terminals are both located in the front and rear panels, both cannot be used at the same time. Leave one side disconnected.

9185 TEST LEAD and 9294 TEST PROBE come with protective caps. Take the caps off before connecting to 3154.

Connect black probe to LOW terminal and red probe to HIGH terminal. Tightly insert probes all the way into the terminals.

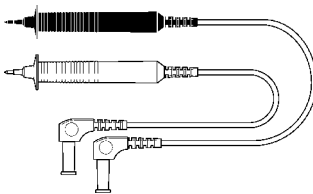

9185 TEST LEAD

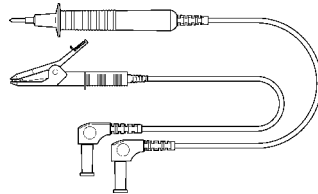

9294 TEST PROBE

2.4 Using Handle

CAUTION

- When using as a stand, excessive downward pressure may damage the handle.
 - When interface cable, etc. is connected to the rear panel, keep the unit flat to avoid damaging the cable.
 - When setting the unit to show display upward, tilt it carefully to avoid damaging power cord by excessive stress.
-

Handle can be used as stand. Pull out the side, turn and press in the handle.

Handle turns each 22.5° .

When setting flat, turn the handle over the unit.

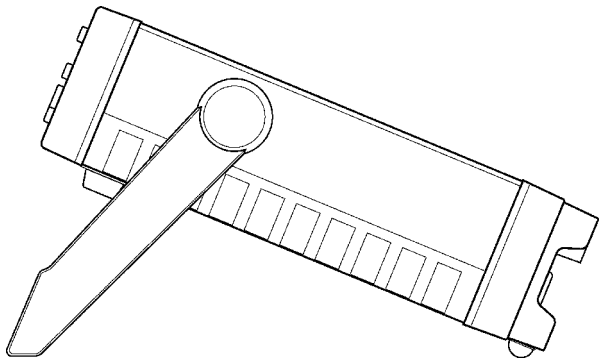

2.5 Connecting to Equipment to be tested



- To avoid the risk of electric shock, turn power off on equipment to be tested.
 - Before and after testing, do not touch equipment to be tested and probe tip when TEST lamp is on or blinking.
 - After testing is complete, confirm that the 3154 TEST lamp is off before disconnecting probe from equipment to be tested.
-



When connecting probe to equipment to be tested under TEST status, verify the voltage occurred on the display before connecting. Improper voltage may damage equipment to be tested.

Connect probe to equipment to be tested.



When 3154 is in READY status, approximately a voltage greater than +10 V volts in equipment to be tested initiates TEST lamp, and blinks after connecting probe.

Chapter 3

Setting Basic Testing Conditions

The below shows setting items and procedures.

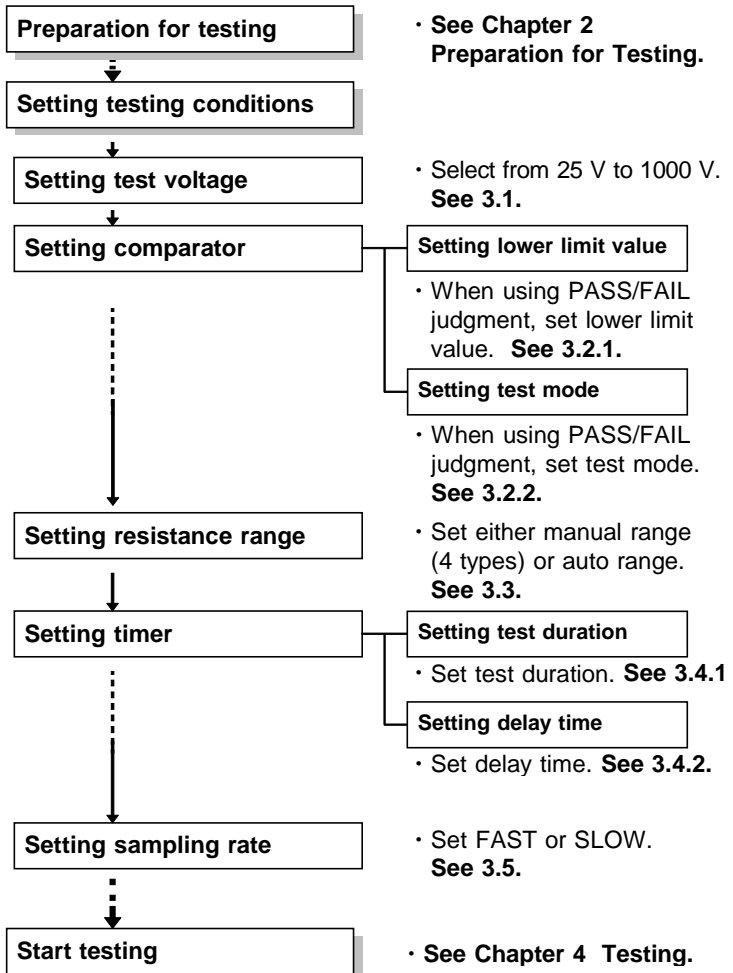

3.1 Setting Test voltage



- Setting at improper voltage may damage equipment to be tested.
- Test voltage can be set by external I/O. In this case, the 3154 test voltage display lamp stays on displaying previous voltage until testing starts after setting voltage from external I/O.

Set and select test voltage from 25 V to 1000 V. To set comparator at each voltage, selecting another voltage automatically changes lower limit value.

■ Setting test voltage

- (1) When READY status (with TEST lamp off or blinking), press VOLT key to initiate test voltage display lamp to blink. (Setting)
- (2) Press ▲/▼ key to select test voltage to start and test voltage indicator lamp starts blinking.
- (3) Press STOP key or VOLT key to complete setting with test voltage indicator lamp no longer blinking but on and returns to READY status.

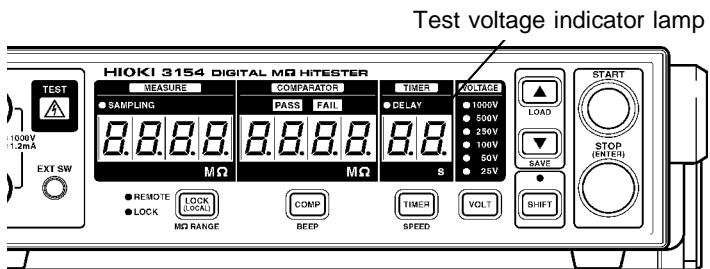

NOTE

- During READY status, TEST status, test voltage can be verified by blinking test voltage indicator lamp.
- When selecting test voltage with external I/O, test voltage cannot be set by key press. Set all external I/O VOLT0 to VOLT2 to LOW or HIGH (not necessary to connect) use key press for setting.

3.2 Setting and Verifying Comparator

3.2.1 Setting Lower Limit Value

When comparator is set, set lower limit value and test mode. Execute PASS/FAIL judgment by comparing value set as lower limit value and measurement value.

Lower limit value determines resistance range for setting (manual range). See the chart below for possible combination of lower limit value and resistance range for setting.

When auto range is selected for resistance range, lower limit value is not limited at any value.

Improper combination of lower limit value and resistance range results in incorrect PASS/FAIL judgment.

See 3.3 Setting and Verifying Resistance Range to set resistance range.

**Test voltage
25 / 50 V**

Lower limit value (M)	Resistance range
0.1/0.2/0.5/1/2	2 M
3/4/5/10/20	20 M
30/50/100/200	200 M

**Test voltage
100/250/500 V**

0.1/0.2/0.5/1/2	2 M
3/4/5/10/20	20 M
30/50/100/200	200 M
300/500/1000/2000	2000 M

**Test voltage
1000 V**

1/2	2 M
3/4/5/10/20	20 M
30/50/100/200	200 M
300/500/1000/2000	4000 M

NOTE

RS-232C Interface provides an option to set lower limit value at any value within the measurement range in addition to the displayed selection. Once designated lower limit value is switched to another by key press, use RS-232C Interface to reset at designated lower limit value.

■ Setting Lower Limit Value

- (1) During READY status, press COMP key and lower limit value indicator starts blinking.

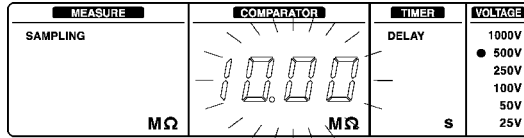

- (2) Press ▲/▼ key to select and display lower limit. (Unit is [MΩ])

"----" appears when comparator is not set.
- (3) Press either STOP key or COMP key to confirm lower limit value.

Display automatically returns to test mode setting display. Continue with test mode setting. See 3.2.2.

■ Not Setting Lower Limit Value (Not Setting Comparator)

- (1) During READY status, press COMP key and comparator lower limit value indicator starts blinking.
- (2) Press both ▲ key and ▼ key at the same time to display "----" blinking or press either ▲/▼ key several times to display "----" blinking.
- (3) Press STOP key or COMP key.
- (4) Returns not to test mode setting status but to READY status. Lower limit value indicator displays "----".

3.2.2 Setting and Verifying Test mode

■ Setting Test mode

- (1) After selecting lower limit value (other than "----") at lower limit value setting status, test mode setting status automatically appears by pressing either STOP key or COMP key.

Which ever display previously set, FAIL StOP or ContinuE starts blinking.

- (2) Press ▲/▼ key to switch FAIL StOP/ContinuE.
FAIL STOP mode: FAIL judgment stops testing.
CONTINUE mode: FAIL judgment does not interfere with testing.
(Testing stops by STOP key press or by time set by timer.)

- (3) Press STOP key or COMP key to confirm selected mode.
After determining selected mode, automatically returns to READY status and displays selected lower resistance value.

■ Confirming Test mode

When lower limit value (excluding "----") is set, follow the instructions below to confirm test mode.

- (1) Press COMP key twice when READY status. Confirm that designated test mode display starts blinking.
- (2) After confirming, press COMP key to return to READY status.

NOTE

- Set test mode adjusted to test voltage.
- When lower limit value is set at "----"(not using comparator), test mode setting is not available.
- Ready status does not display test mode.

3.3 Setting and Verifying Resistance Range

Resistance range comes with four types of manual range, 2 M Ω , 20 M Ω , 200 M Ω , 2000 M Ω (4000 M Ω at 1000 V) and auto range.

Auto range may require some time before measurement value is displayed because range has to shift immediately after testing starts. Set resistance range to manual range according to measuring object to eliminate time to display.

■ Setting Resistance Range

- (1) Press SHIFT key, then LOCK key when READY status. Display as shown below appears and lower limit value indicator blinks and displays one of the following "AUtO", "2", "20", "200", "2000". ("4000" at 1000 V)

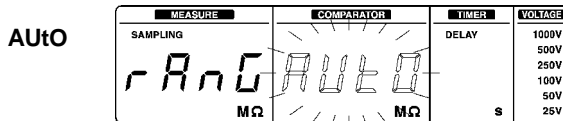

- (2) Each ▲/▼ key press switches blinking display.
- (3) When desired resistance range is displayed, press STOP key or LOCK key to confirm. After determining, returns to READY status.

When manual range is selected and measurement value is over 2000 count, "O.F." (Over flow) is displayed. When measurement value is less than 190 count, "U.F." (Under flow) is displayed.

■ Confirming Resistance Range

- (1) Press SHIFT key, then LOCK key when READY status to display selected resistance range blinking.
- (2) After confirming, press STOP key or LOCK key to return to READY status.

3.4 Setting and Verifying Timer

3.4.1 Setting and Verifying Test Duration

Test duration is the time to apply voltage, measure resistance and perform PASS/FAIL judgment. Same Test duration setting is applicable at any test voltage.

■ Setting Test duration

- (1) During READY status, press TIMER key and timer indicator starts blinking.

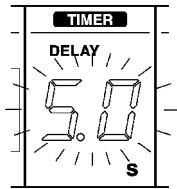

- (2) Press ▲/▼ key to display desired test duration at timer indicator.
Hold ▲/▼ key down to speed up adjustment of timer control. (units in [seconds], setting range: 0.5 s to 99 s)
"--" is displayed when test duration is not set.
- (3) Press STOP key or TIMER key to confirm test duration. Indicator automatically switches and displays delay time setting status and timer display and DELAY lamp start blinking. To set delay time, see 3.4.2.

■ When Not Setting Test duration

- (1) During READY status, press TIMER key. When timer indicator is blinking, press both ▲ key and ▼ key at the same time to display "--" blinking or hold down either ▲ key or ▼ key to display "--" blinking.
- (2) When "--" is blinking, press STOP key or TIMER key.
- (3) After setting delay time, returns to READY status. Timer indicator displays "--" .
In this case, testing is performed with no time limit.

3.4.2 Setting and Verifying Delay Time

Delay time is used to set test duration lock out time for timer function and PASS/FAIL judgment by comparator immediately after testing starts and voltage is applied. Measurement value is displayed.

Same delay time setting is applicable at any test voltage. For details, read 3.4.3 Determining Delay time.

■ Setting Delay Time

- (1) During test duration setting status, press STOP key or TIMER key to automatically change and display delay time settings display.

Timer display and DELAY lamp start blinking.

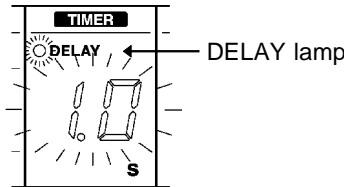

- (2) Press ▲/▼ key to display desired delay time on timer indicator.
Hold ▲/▼ key down to speed up adjustment of timer control. (units in [seconds], setting range: 0.1 s to 99 s)
- (3) Press STOP key or TIMER key to confirm delay time.
After determining, automatically returns to READY status and DELAY lamp is turned on.
Timer indicator displays selected test duration.

■ When Not Setting Delay Time

- (1) During delay time setting status, press both ▲ key and ▼ key at the same time to display "--" blinking or hold down either ▲ key or ▼ key to display "--" blinking.
- (2) When "--" is blinking, press STOP key or TIMER key.
- (3) Returns to READY status. In this case, testing is performed as 0 second delay time.

■ Confirming Delay Time

During READY status, delay time is not displayed. Follow the direction below to confirm delay time.

- (1) During READY status, press TIMER key twice.
Selected delay time is displayed with DELAY lamp blinking. When delay time is not set, "--" is displayed with DELAY lamp blinking.
- (2) After confirming, press TIMER key to return to READY status.

3.4.3 Determining Delay Time

When equipment to be tested contains capacitance, measurement value is low due to current charging capacitance immediately after test voltage is applied resulting in FAIL judgment by comparator. To avoid incorrect FAIL judgment, set delay time.

While charging capacitance, time is required for applied voltage to reach test voltage standard value. Because test duration countdown begins after time elapses when confirmed as delay time, it provides an option for a test with test duration excluding charging time (during low voltage).

Determine delay time by examining measurement value fluctuation after start of testing and applied voltage rising waveform (observed with optional tester).

Without Delay Time

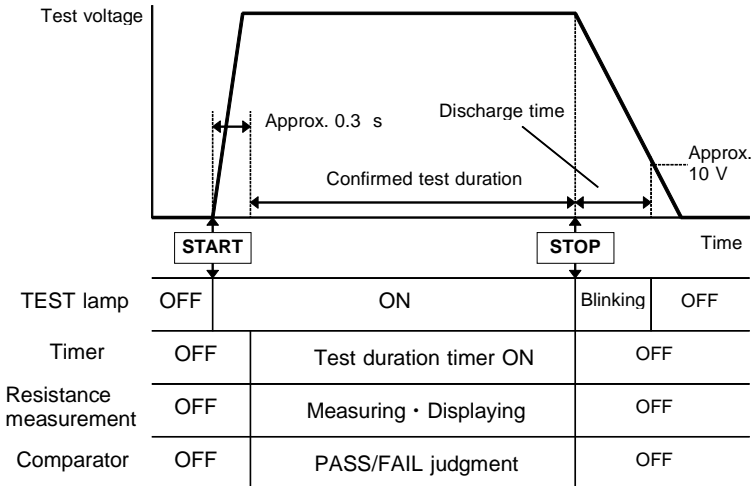

With Delay Time

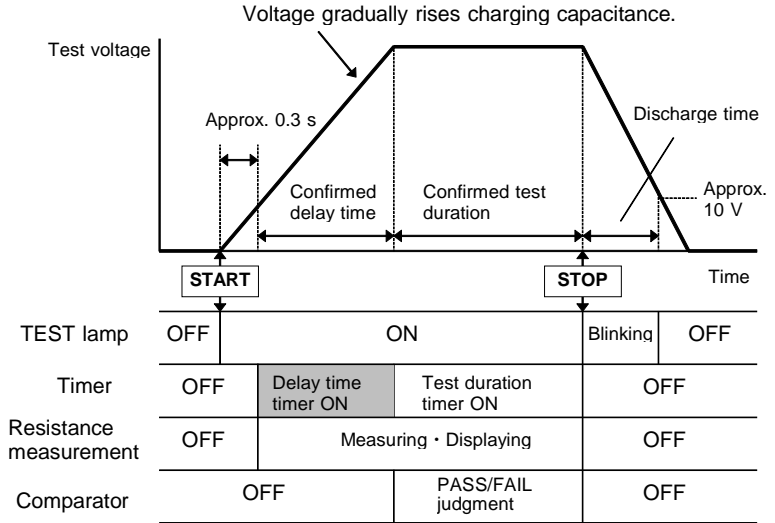

3.5 Setting Sampling Rate

Choose from two sampling rates, FAST or SLOW. Sampling resistance and displaying value with FAST is ten times per second and with SLOW one time per second. When measurement value fluctuates, select SLOW for effective reading. During TEST status, SAMPLING lamp blinking rate alter according to sampling rate. To confirm selected sampling rate check the lamp blinking rate.

■ Setting Sampling Rate

- (1) During READY status, press SHIFT key and then TIMER key.

Display appears as shown below to display sampling rate FAST or SLOW blinking.

FAST	MEASURE	COMPARATOR	TIMER	VOLTAGE
	SAMPLING SPEED MΩ	FAST MΩ	DELAY s	1000V 500V 250V 100V 50V 25V
SLOW	MEASURE	COMPARATOR	TIMER	VOLTAGE
	SAMPLING SPEED MΩ	SLO MΩ	DELAY s	1000V 500V 250V 100V 50V 25V

- (2) Press ▲/▼ key to switch blinking display.
- (3) When selected sampling rate is displayed, press STOP key or TIMER key to confirm. After confirming, returns to READY status.

3.6 Example Test Condition Setting

The example shows READY status setting display after setting is complete before START key is pressed.

Measurement value display decimal position may differ case by case.

When returning to READY status without changing previous setting condition, the last measurement value and PASS/FAIL judgment result are displayed again.

- (1) When testing with comparator and timer and judging PASS/FAIL with beep sound, set as instructed below.

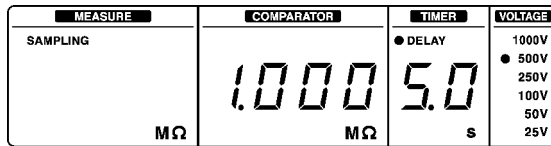

Test voltage	500 V	Lower limit value	1 MΩ
Test duration	5 s	Test mode	FAIL STOP
Delay time	ON	Judgment beep sound	END(see 5.1.1)

Test mode, delay time and beep sound setting are not displayed during READY status.

Start testing with above settings. While timer is ON, FAIL judgment stops test followed by an approximately two second continuous beep sound. When test duration timer ends, short beep sound repeats three times.

When FAIL STOP mode is set, completing test duration with timer indicates PASS judgment.

Single continuous beep sound indicates FAIL and repeating beep indicates PASS judgment.

(2) Exclusively for insulation resistance measurement, set as instructed below.

MEASURE	COMPARATOR	TIMER	VOLTAGE
SAMPLING		DELAY	1000V
	— — — —	— —	● 500V
			250V
			100V
			50V
			25V
MΩ	MΩ	s	

Test voltage	500 V	Lower limit value	No limit
Test duration	OFF	Test mode	- - -
Delay time	OFF		

Chapter 4

Testing

HIOKI 3154 DIGITAL M Ω HiTESTER is equipped with READY status, setting status and TEST status.

- (1) READY status
Stands ready for testing. TEST lamp is either OFF or blinking during READY status.
- (2) Setting status
Sets various test settings. Each setting display blinks during setting status.
- (3) TEST status
To test with voltage between measurement terminals. TEST lamp is ON during TEST status.

NOTE

See 4.7 Testing with 9299 SWITCHED PROBE to conduct measurement using 9299 SWITCHED PROBE.

4.1 Test Flow

Simple test flow chart

- During READY status, press START key to start testing.
- Switches to TEST status and TEST lamp is ON.

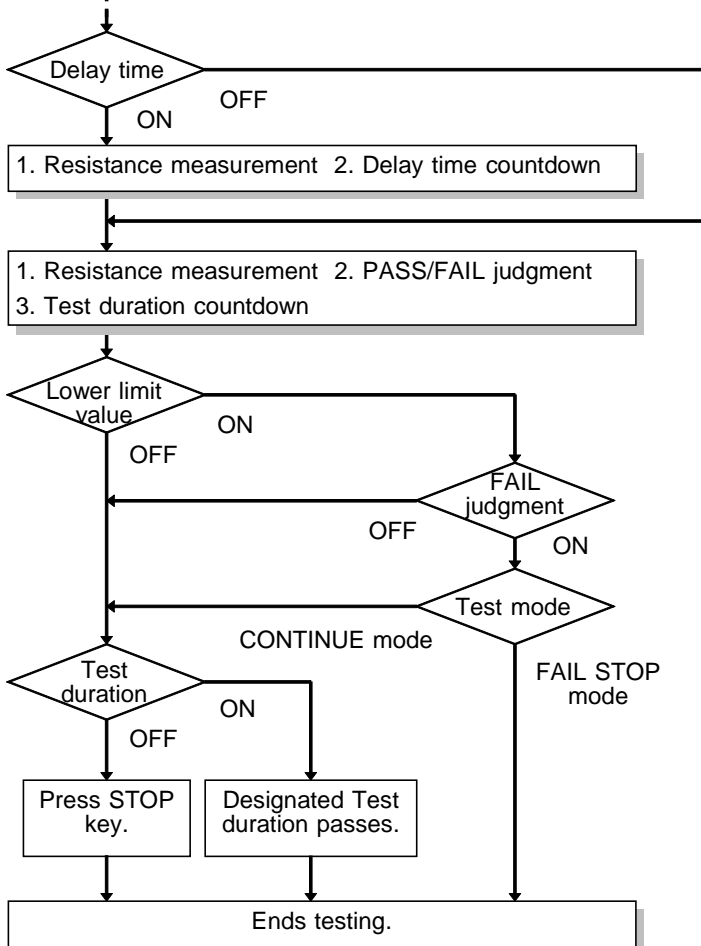

- Returns to READY status.
Continues to display measurement value and judgment result (when lower limit value is set).
- For safety, discharge charge buildup in tested equipment.
During discharge, TEST lamp blinks.

4.2 Start Testing



- To avoid the risk of electric shock, do not touch equipment to be tested, probe tips and measurement terminals when TEST lamp is on or blinking.
- Do not touch equipment to be tested, probe tips and measurement terminals immediately after testing. High voltage charge may result in electric shock.
- After testing, proceed with discharge function to discharge charge in tested equipment. (See 4.6.)

During READY status, press START key to start testing in TEST status with TEST lamp ON.

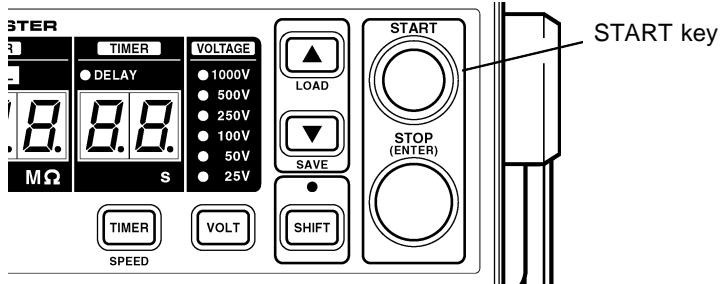

NOTE

- To start and end testing, in addition to keys, 3154 DIGITAL MΩ HiTESTER is equipped with external I/O, RS-232C and probes with switch. Different ways can be used to start and to end testing.
- Check and see if measurement probes are securely connected before testing.
- When external I/O STOP signal is set to LOW, testing does not start.

4.3 During Testing (TEST status)

When switching to TEST status, the 3154 applies test voltage to equipment to be tested.

1. When delay time is set, starts resistance measurement and delay time countdown.
For details, see 3.4.3 Determining Delay time.
 - (1) Starts resistance measurement and displays measurement value. (unit: $M\Omega$)
 - (2) During delay time countdown, DELAY lamp blinks. After completing delay time countdown, DELAY lamp goes OFF.

2. After passing delay time (or without setting delay time), starts resistance measurement, PASS/FAIL judgment and test duration countdown.
 - (1) Starts resistance measurement and displays measurement value. (unit: $M\Omega$)
 - (2) Following resistance measurement, performs PASS/FAIL judgment by comparator.
When measurement value $<$ lower limit value, FAIL lamp turns ON.
When measurement value \geq lower limit value, PASS lamp turns ON.
See 5.1.1 to set beep sound for judgment.
When lower limit value is not set, lower limit value indicator displays "----" without PASS/FAIL judgment.
 - (3) Timer indicator indicates test duration countdown.
When test duration is not set, indicator displays "--".

NOTE

- Approximately 0.3 s is required after pressing START key to start resistance measurement and delay time countdown.
- See 4.4 to display measurement value.

4.4 Measurement Value Display

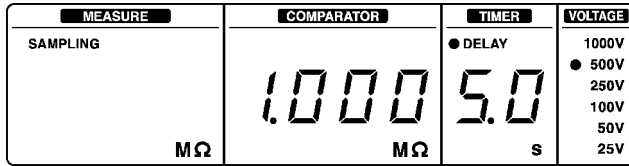

Tips for measurement value display

- When resistance range is set to auto range, range shifts immediately after testing starts and only decimal point moves and measurement value is not displayed on measurement value display. To eliminate time for decimal point to move, switch resistance range to manual range. (See 3.3 for setting.)
- When set at auto range, measurement value fluctuates between two resistance ranges. In this case switch resistance range to manual range. (See 3.3 for setting.)
- Display "O.F." indicates overflow. In auto range, "O.F." is displayed when going over measurement range maximum value and in manual range when over each range maximum value.
- Display "U.F." indicates underflow. In manual range, excluding 2 MΩ range, "U.F." is displayed when going below 190 dgt. Does not display in auto range.
- Insulation resistance is known to be unstable. This is not a difficulty although measurement values may not be consistent depending on the equipment to be tested.
- When measurement values fluctuate and are unable to read, set sampling rate to SLOW. (See 3.5)
- Larger capacitance in equipment to be tested tends to result in a wider range of measurement value fluctuations. See capacitance reference chart in Chapter 8.

4.5 Completing Testing

- (1) After ending testing by one of three following ways, returns to READY status.
 - Press STOP key to stop testing.
 - Designated testing time passes and stops testing.
 - When test mode is set at FAIL STOP mode, FAIL judgment stops testing.
- (2) After returning to READY status, previously displayed measurement value and judgment result display lamp at testing completion continue to display.

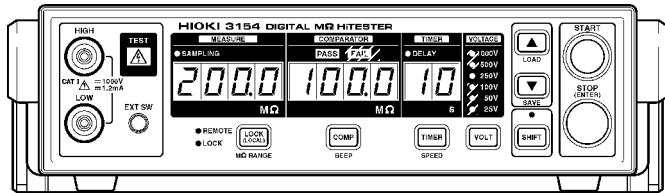

- (3) Blinking TEST lamp after testing indicates discharge of buildup in progress in tested equipment. Proceed with discharge by following instruction in 4.6 Automatic Discharge.
- (4) After TEST lamp is turned off, remove probes from tested equipment.

4.6 Automatic Discharge

When insulation resistance test is performed on equipment to be tested containing capacitance, test voltage load is charged during testing which may result in electric shock. Use automatic discharge function to discharge buildup charge through the 3154 internal circuit.

After testing, follow the instructions below to discharge.

- (1) End testing without removing both test probes from tested equipment.
- (2) The 3154 internal discharge resistance unit enables automatic discharge of the buildup charge in the tested equipment.
- (3) During discharge, TEST lamp blinks.
- (4) When voltage goes below approximately 10 V, TEST lamp turns off.
Internal discharge resistance is approximately 2 M Ω .
Larger amount of capacitance requires longer discharge time.

NOTE

- Safe to set and verify test condition setting or press START key to restart testing while TEST lamp is still blinking.
- When the 3154 power supply is turned OFF, discharge resistance is approximately 12 M Ω .

4.7 Testing with 9299 SWITCHED PROBE

Optional 9299 SWITCHED PROBE permits control starting and stopping 3154 operation while probe is held in hand. Before testing, set push switch probe mode to either trigger mode or continue mode. (See 4.7.2 to set mode.) The 3154 initial setting is set to continue mode.

(1) Continue Mode

Only when pressing ON switch, continues TEST status. During READY status, press switch to start testing. Release switch to terminate testing.

(2) Trigger Mode

Press switch to start testing. TEST status continues even after releasing switch. Press switch to terminate testing in TEST status.

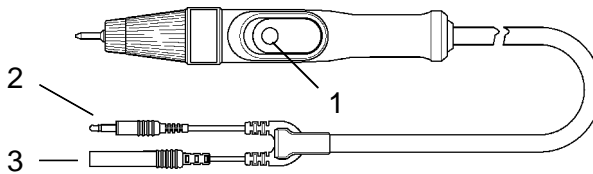

1. Push switch	Functions as external switch for the 3154 START key and STOP key.
2. Switching signal lead plug	Connects to the 3154 EXT SW terminal.
3. Measurement plug	Connect to the 3154 measurement terminal.

NOTE

- The same operations are applicable in both TEST status and READY status.
- 9299 SWITCHED PROBE can be used as an ordinary probe when switch signal lead plug is not connected to EXT SW terminal.
- When external I/O STOP signal is set to LOW or the 3154 STOP key is pressed, testing cannot be initiated.

4.7.1 Connecting 9299 SWITCHED PROBE



- Inserting switch signal lead plug into terminal may turn TEST lamp on causing high voltage to occur in measurement terminal and probe tip. Before connecting switch signal lead plug to 3154, make sure to disconnect measurement probe from measurement terminal.
- Do not press switch on probe when connecting and disconnecting probe.

9299 SWITCHED PROBE requires another measurement probe. Use either 9185 or 9294 probe.

Follow these steps carefully to connect probe.

- (1) Connect 9299 switch signal lead plug to EXT SW terminal.

Insert plug securely so that plug metal tip is not exposed at all.

When TEST lamp is on after inserting plug, press switch on 9299 or press 3154 STOP key to turn TEST lamp off.

- (2) After confirming TEST lamp is turned off, connect 9299 measurement plug to front panel HIGH or LOW measurement terminal.
- (3) Connect another measurement probe (9185 or 9294) to the other front panel measurement terminal.
- (4) When 3154 is in READY status, press switch on 9299 and verify that 3154 TEST lamp is turned on.

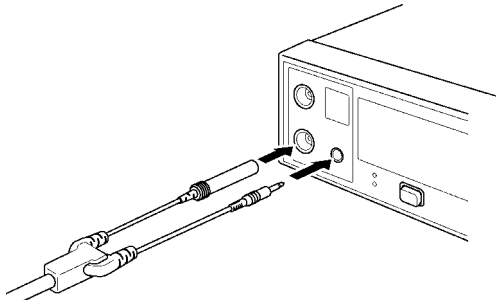

When disconnecting 9299 from the 3154, disconnect measurement probe first and signal lead last.

4.7.2 Setting 9299 SWITCHED PROBE

Select either continue mode (cont) or trigger mode (trig) to set 9299 SWITCHED PROBE.

■ Operation Setting

- (1) During READY status, press SHIFT key then press and hold VOLT key for approximately two seconds or longer to display "SPECIAL".

MEASURE	COMPARATOR	TIMER	VOLTAGE
SAMPLING		DELAY	1000V
SPECIAL	SPECIAL		500V
MΩ	MΩ	s	250V
			100V
			50V
			25V

- (2) Press / key to display "9299 Probe".

MEASURE	COMPARATOR	TIMER	VOLTAGE
SAMPLING		DELAY	1000V
9299	Probe		500V
MΩ	MΩ	s	250V
			100V
			50V
			25V

- (3) Press STOP key and "9299 Cont" or "9299 triG" appear blinking to show display to select and set Push Switch probe mode setting. (Display "9299" does not blink.)

Continue mode

MEASURE	COMPARATOR	TIMER	VOLTAGE
SAMPLING		DELAY	1000V
9299	Cont		500V
MΩ	MΩ	s	250V
			100V
			50V
			25V

Trigger mode

MEASURE	COMPARATOR	TIMER	VOLTAGE
SAMPLING		DELAY	1000V
9299	triG		500V
MΩ	MΩ	s	250V
			100V
			50V
			25V

- (4) Press ▲/▼ key to switch blinking display with "Cont" or "triG".
- (5) Display blinking "Cont" to switch to continue mode and "triG" to trigger mode and press STOP key. After pressing STOP key, probe operation mode is confirmed and returns to READY status.

Chapter 5

Other Functions

3154 is equipped with the following functions.

Setting and Verifying Beep Sound

Setting Judgment Beep

• See 5.1.1.

Setting Beep Sound During Key Press

• See 5.1.2.

Saving and Loading Test Conditions

Saving Test Conditions

• See 5.2.1.

Loading Test Conditions

• See 5.2.2.

Key Lock Function

• See 5.3.

System Reset

• See 5.4.

5.1 Setting and Verifying Beep Sound

5.1.1 Setting Judgment Beep Sound

When PASS/FAIL judgment is performed with comparator and timer, select beep sound from following four options.

PASS : Beeps for PASS judgment.

FAIL : Beeps for FAIL judgment.

End : Beeps when test duration timer ends.

OFF : No beep sound.

■ Setting Judgment Beep Sound

- (1) During READY status, press SHIFT key and then COMP key.

Display appears blinking to indicate selected beep sound option. (Example below shows when beep sound is OFF.)

MEASURE	COMPARATOR	TIMER	VOLTAGE
SAMPLING bEEP MΩ	OFF MΩ	DELAY s	1000V 500V 250V 100V 50V 25V

- (2) Each ▲/▼ key press switches blinking displays "PASS", "FAIL", "End", "OFF" to indicate options.
- (3) Press either STOP key or COMP key to confirm the option. After confirming, automatically returns to READY status.

■ Verifying Judgment Beep Sound

- (1) During READY status, press SHIFT key and then COMP key. Verify that selected beep sound option indicator is blinking.
- (2) After verifying, press either STOP key or COMP key and returns to READY status.

5.1.2 Setting Beep Sound During Key Press

Select from beep sound options to set beep ON or OFF during key press.

■ Setting Beep Sound ON or OFF.

- (1) During READY status, press SHIFT key then press and hold VOLT key for approximately two seconds or longer to display "SPECIAL".

MEASURE	COMPARATOR	TIMER	VOLTAGE
SAMPLING SPECIAL MΩ	COMPARATOR SPECIAL MΩ	DELAY s	1000V 500V 250V 100V 50V 25V

- (2) Press / key to display "KEY bEEP".

MEASURE	COMPARATOR	TIMER	VOLTAGE
SAMPLING KEY bEEP MΩ	COMPARATOR KEY bEEP MΩ	DELAY s	1000V 500V 250V 100V 50V 25V

- (3) Press STOP key and "bEEP ON" or "bEEP OFF" appears blinking to select and set beep sound during key press. (Display "bEEP" does not blink.)

Beep ON

MEASURE	COMPARATOR	TIMER	VOLTAGE
SAMPLING bEEP ON MΩ	COMPARATOR bEEP ON MΩ	DELAY s	1000V 500V 250V 100V 50V 25V

Beep OFF

MEASURE	COMPARATOR	TIMER	VOLTAGE
SAMPLING bEEP OFF MΩ	COMPARATOR bEEP OFF MΩ	DELAY s	1000V 500V 250V 100V 50V 25V

- (4) Each ▲/▼ key press switches blinking displays "ON" and "OFF".
- (5) Select blinking indicator "ON" to set beep sound on and "OFF" to set off and press STOP key to confirm option. After confirming, automatically returns to READY status.

5.2 Saving and Loading Test Conditions

5.2.1 Saving Test Conditions

All 3154 configured test conditions, up to ten settings can be saved in internal memory excluding the following four conditions.

Special Conditions

- 9299 SWITCHED PROBE operation mode
- Changing RS-232C Interface options (personal computer/printer)
- Beep sound setting during key press
- External I/O TEST signal OFF timing setting

Read saved memory by operation instructed in 5.2.2 Loading Test Conditions.

■ Saving Test Conditions

- (1) During READY status, press SHIFT key and then ▼ key. Following indicator appears displaying a number blinking to display save setting. The number identifies test condition setting to be saved.

When save setting display appears, the number displayed is determined as described below.

- Displays the smallest number available if not all ten numbers are used.
- Displays number 10 if all ten numbers are already in use to identify and save settings.

MEASURE	COMPARATOR	TIMER	VOLTAGE
SAMPLING		DELAY	1000V
SAVE			500V
MΩ	MΩ	s	250V
			100V
			50V
			25V

- (2) Press ▲/▼ key to select desired number from option 1 to 10 to save settings. (When a saved option is selected, overwrites previous test condition settings.)
- (3) Press STOP key. Display "SAVE NO." blinks approximately two seconds or returns to READY status completing saving test conditions.
To return to READY status without saving test conditions, press any key except STOP key and ▲/▼ key.

5.2.2 Loading Test Conditions

Saved test conditions can be loaded from internal memory.

■ Loading saved test conditions

- (1) During READY status, press SHIFT key and then ▲ key. Following indicator appears displaying a number blinking. The number identifies saved test condition setting.

MEASURE	COMPARATOR	TIMER	VOLTAGE
SAMPLING LOAD MΩ	 MΩ	DELAY s	1000V 500V 250V 100V 50V 25V

- (2) Press ▲/▼ key to select option to load. Does not display numbers not in use.
- (3) Press STOP key. Display "LOAD No." appears blinking approximately two seconds and returns to READY status completing loading test condition.
To return to READY status without loading test conditions, press any key except STOP key and ▲/▼ key.
- (4) Each indicator displays loaded conditions.

NOTE

- When loading with test voltage setting signal input through external I/O, following loaded conditions; test voltage, lower limit value and test mode become invalid defaulting to external I/O setting even after pressing START key.
- When no condition setting is saved, loading display shows "--" in stead of number. In this case pressing ▲/▼ key does not switch displays.

5.3 Key Lock Function

Execute key lock to disable front panel key switch operations excluding START key, STOP key and 9299 SWITCHED PROBE switching operations.

■ Executing Key Lock

During READY status, press and hold LOCK key for approximately two seconds or longer.

When key lock status, LOCK lamp on the left of LOCK key is on.

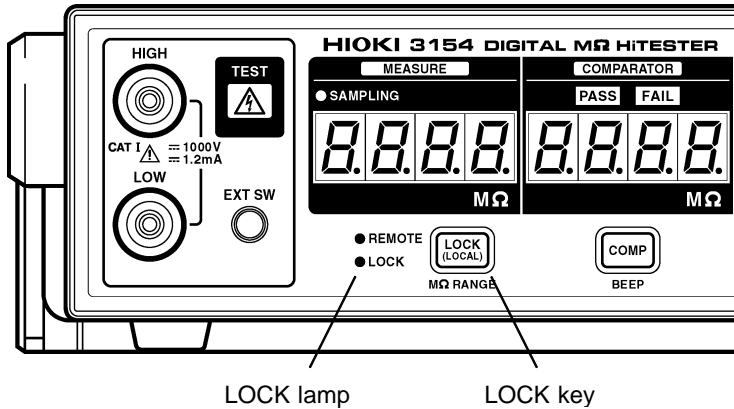

■ Disengaging Key Lock

During READY status, press and hold LOCK key for approximately 2 s or longer.

5.4 System Reset

System reset is used to set all test conditions back to initial factory settings. All saved test conditions are cleared by system reset.

■ Executing system reset

- (1) During READY status, press SHIFT key then press and hold VOLT key for approximately two seconds or longer to display "SPECIAL".

MEASURE	COMPARATOR	TIMER	VOLTAGE
SAMPLING		DELAY	1000V
SPECIAL	SPECIAL		500V
MΩ	MΩ	s	250V
			100V
			50V
			25V

- (2) Press / key several times to display "rESEt".

MEASURE	COMPARATOR	TIMER	VOLTAGE
SAMPLING		DELAY	1000V
rESEt			500V
MΩ	MΩ	s	250V
			100V
			50V
			25V

- (3) Press STOP key and all indicators are turned on. After displaying "Product name" and "Software version", returns to READY status completing system reset.

Factory Settings

Test voltage	25 V
Lower limit value	OFF (displays [----])
Test mode	Continue mode
Test duration	OFF (displays [--])
Delay time	OFF (displays [--])
Resistance range	Auto range
Judgment beep sound	FAIL
Sampling rate	FAST
Push switch probe mode	Continue mode
Beep sound during key press	ON
Connection with RS-232C	PC
External I/O TEST signal OFF timing	SLOW

Chapter 6

External Interface

6.1 Controlling 3154 with External I/O

External I/O terminal connector board is located in the back and enables signal input for START • STOP • test voltage control and signal output for 3154 status (TEST status, etc.) • comparator judgment results.

All signal leads are isolated through a photocoupler from other parts. (Not isolated between signal leads)

Use external power supply (5 to 30 VDC).

Internal power supply 5 V and GND are output by external I/O terminal enabling simple external I/O functions. Use caution because external I/O, RS-232C connector and analog output terminal are not isolated.

6.1.1 Terminal Connector Board/Signal Wires

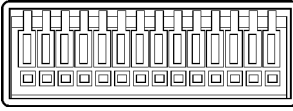

1 14

Pin number	IN/OUT	Signal name
1, 2	OUT	INT.GND
3	IN	EXT.COM
4	OUT	FAIL
5	OUT	PASS
6	OUT	TEST
7	IN	VOLT2
8	IN	VOLT1
9	IN	VOLT0
10	IN	STOP
11	IN	START
12	IN	EXT.DCV
13, 14	OUT	INT.DCV

START	Set signal to LOW to enable same function as pressing 3154 START key. To perform start up edge detection, it requires more than 60 ms when set to LOW. Locking on LOW does not release continuous START signal input. In this case STOP signal is accepted for input.
STOP	Set signal to LOW to enable same function as pressing 3154 STOP key. To perform start up edge detection, it requires more than 60 ms when set to LOW. Locking on LOW does not accept "all test start" for input.
VOLT0,VOLT1, VOLT2	Signal combinations allow six test voltage (including comparator) setting options. (See Test Voltage Control Chart)
TEST	During TEST status, selects LOW. Set with options either to wait until after discharging charge in tested equipment after completing test or not to wait and returns to HIGH. See 6.1.5.
PASS	Selects LOW when comparator gives PASS judgment.
FAIL	Selects LOW when comparator gives FAIL judgment.
EXT.DCV	Terminal to supply power from external equipment. Power supply voltage range is 5 to 30 VDC. Supplies power also by connecting with INT.DCV terminal.

EXT.COM	Terminal to connect to external equipment GND. Also connects with INT.GND terminal.
INT.DCV, INT.GND	Outputs 3154 internal power supply (DC+5 V) and internal GND. Use to enable simple external I/O functions. Not isolated. GND terminal is connected with power supply cord ground lead.

Test Voltage Control Chart

Signal \ Test voltage	Test voltage							Invalid	
	25 V	50 V	100 V	250 V	500 V	1000 V	L	H	
VOLT0	L	H	L	H	L	H	L	H	
VOLT1	H	L	L	H	H	L	L	H	
VOLT2	H	H	H	L	L	L	L	H	

"H" stands for HIGH, "L" for LOW.

NOTE

- Beep sound can be set to ON/OFF during START and STOP signal input. Same setting applies and performs same operation as beep sound during key press.
- To avoid starting test by mistake, hold STOP signal LOW and set it back to HIGH right before setting START signal to LOW. In this case, be sure to set STOP signal to HIGH at least 1 ms before START signal is set to LOW.

6.1.2 Electric Specifications

Input signal specifications

(Applied signal names: START, STOP, VOLT0, VOLT1, VOLT2)

Input signal	Active LOW input
Maximum applied voltage	5 VDC
HIGH level	5 VDC or open
LOW level	0.3 VDC or less

Output signal specifications

(Applied signal names: PASS, FAIL, TEST)

Output signal	Open corrector output
Maximum load voltage	DC+30 V (when not using EXT.DCV terminal)
Maximum output current	60 mADC/1 signal (when LOW level)

EXT.DCV terminal maximum input voltage: 30 VDC input to EXT.COM terminal

Internal power supply output

(between INT.DCV and INT.GND terminals)

Output voltage	5 VDC
Maximum load current	100 mADC

Output signal is a photocoupler open corrector output. 3154 is internally connected to EXT.DCV terminal at 4.7 k Ω pull up resistance.

When Not Using EXT.DCV Terminal

When connecting and loading directory to output terminal without using EXT.DCV terminal, refer to the chart below for external DC power supply to be connected for another direct loading and output signal voltage, output current.

External DC power supply	Output voltage			
	High level	Low level		
		Output current 10 mA	Output current 40 mA	Output current 60 mA max.
5 V	5 V	0.9 V	1.1 V	1.2 V
12 V	12 V	0.9 V	1.1 V	1.2 V
24 V	24 V	0.9 V	1.1 V	1.2 V

6.1.3 Connecting External I/O Terminal



CAUTION

- In order to avoid risk of damaging the unit, do not input excessive voltage or current above standard to external I/O terminal. See "6.1.2 Electric Specifications" to set standard voltage and current.
 - 5 VDC is output between internal DC power supply(INT.DCV) and INT.GND. Maximum current is 100 mA. Do not connect to external circuit consuming more than 100 mA.
 - Power supply voltage to external DC power supply (EXT.DCV, EXT.COM terminals) is 5 to 30 VDC. To prevent equipment damage, do not apply voltage over 30 VDC. In order to activate circuit, connect power supply with at least 50 mA output capacity.
 - In order to avoid risk of electric shock, turn equipment power supply OFF before connecting and disconnecting wires to terminal board. Carefully handle wiring and see that no wire is disconnected and exposing conducting elements including the unit body etc.
 - When using relay, be sure to install back electromotive force absorption diode.
 - Do not short circuit terminals other than designated terminals. Internal short circuit may occur when sheathing is exposed beyond standard length.
-

- (1) Push the tab with a flatblade screwdriver or similar.
- (2) While keeping the tab depressed, insert a stripped wire into the connector opening.
- (3) Release the tab to lock the wire.

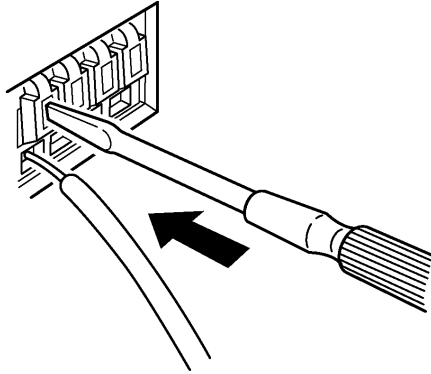

Recommended wire	Single strand	0.65 mm dia (AWG#22)
	Multi-strand	0.32 mm ² (AWG#22)
Usable limits	Single strand	0.32 to 0.65 mm dia. (AWG #28 to #22)
	Multi-strand	0.08 to 0.32 mm ² (AWG #28 to #22)
Standard insulation stripping length		10 mm
Button pressing tool	Blade screwdriver (tip width 2.6 mm)	

6.1.4 External I/O Terminal Circuit



- Signal wire insulation is used to cut down interference between signals. Be sure to apply protective grounding to external equipment to be connected to avoid risk of damaging insulation.
 - Maximum photocoupler low level output current is 60 mA. When more than 60 mA current is required, current amplifier transistor circuit and other external power supply devices must be connected externally.
-

External I/O terminal circuit schematic diagram shown below.

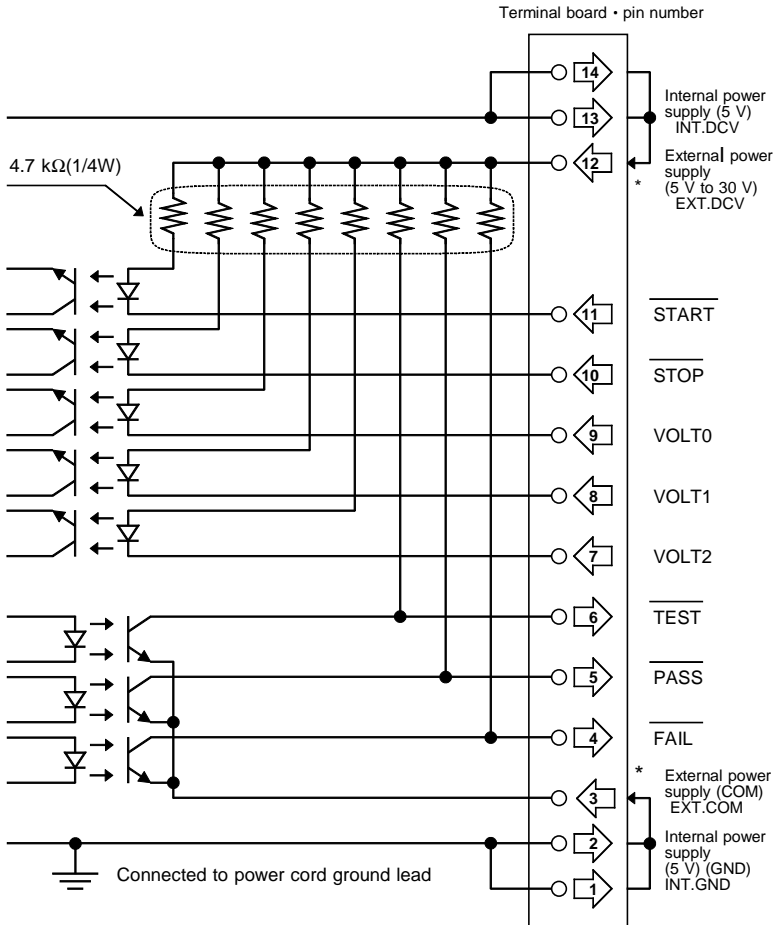

* : Connect when using internal DC power supply (5 V).

6.1.5 Setting TEST Signal OFF Timing

The following shows two options when external I/O TEST signal output returns from LOW to HIGH after completing test. Factory setting is set to SLOW.

(1) SLOW (SLO)

After completing test, maintains LOW (same status during test) until voltage goes down to approximately 10 V in tested equipment during discharge.

(2) FAST (FASt)

Regardless of discharging status, returns to HIGH almost simultaneously after completing test.

■ Setting TEST signal OFF timing

- (1) During READY status, press SHIFT key and press and hold VOLT key approximately two seconds or longer to display "SPECIAL".

MEASURE	COMPARATOR	TIMER	VOLTAGE
SAMPLING SPECIAL MΩ	COMPARATOR SPECIAL MΩ	DELAY s	1000V 500V 250V 100V 50V 25V

- (2) Press / key to display "I-O SIGNAL"

MEASURE	COMPARATOR	TIMER	VOLTAGE
SAMPLING I-O MΩ	COMPARATOR SIGNAL MΩ	DELAY s	1000V 500V 250V 100V 50V 25V

- (3) Press STOP key to display either "I-O SLO" or "I-O FASt" blinking and display appears to set TEST signal to OFF timing. ("I-O" does not blink.)
- (4) Press ▲/▼ key to switch blinking displays "SLO" and "FASt".
- (5) After selecting "SLO" or "FASt", press STOP key to confirm option and returns to READY status.

■ Verifying setting

Just to verify setting, just go to setting display. After verifying blinking indicator, press STOP key to return to READY status.

■ TEST Signal OFF Timing

(1) When SLOW is selected

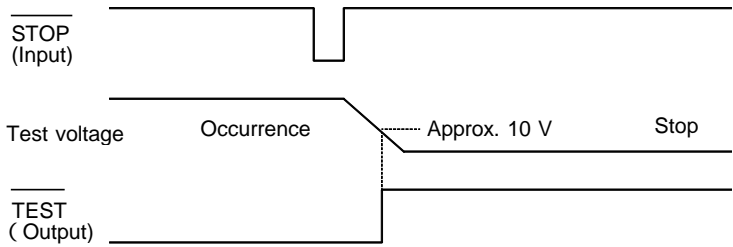

(2) When FAST is selected

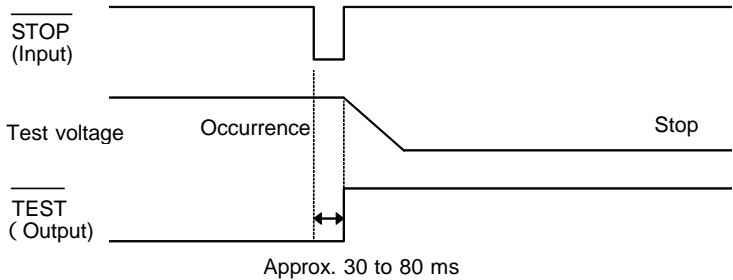

6.1.6 Timing Chart

To control test voltage from external I/O, set signal before testing. Test voltage cannot be changed during testing.

TEST signal timing is synchronized with front panel TEST lamp.

Delay time	OFF	Resistance range	Manual range
Start testing	START signal	End testing	STOP signal
First judgment result	PASS	After second judgment result	FAIL
TEST signal OFF timing		SLOW	

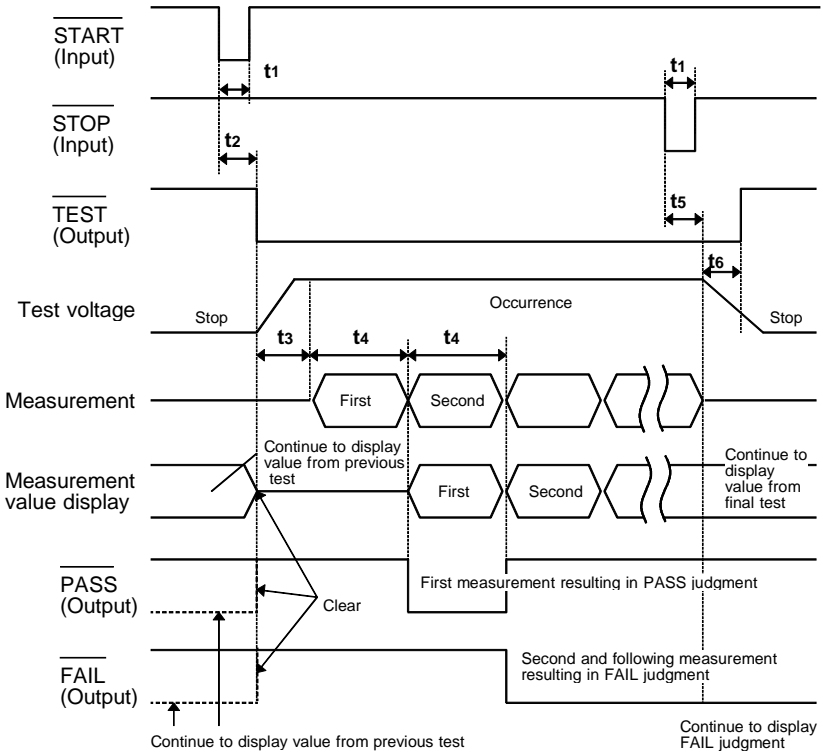

Timing		Time
t1	START signal range, STOP signal range	60 ms min.
t2	Between START input and TEST signal output	80 ms max.
t3	Between TEST signal output and measurement starting time	Approx. 250 ms
t4	Sampling time	FAST 0.1 s/SLOW 1 s
t5	Between STOP signal input and time when test voltage starts falling.	80 ms max.
t6	Between time when test voltage stops and time when TEST signal is disengaged.(HIGH) Note: Reference value when measuring pure resistance 10 M	Test voltage: 25 V approx. 150 ms Test voltage: 1000 V approx. 600 ms

The timing chart below shows timing between time to start and time to complete testing under the following conditions.

Delay time	OFF	Resistance range	Manual range
Start testing	START signal	End testing	End of setting time
First judgment result	PASS	After second judgment result	FAIL
TEST signal OFF timing		SLOW	

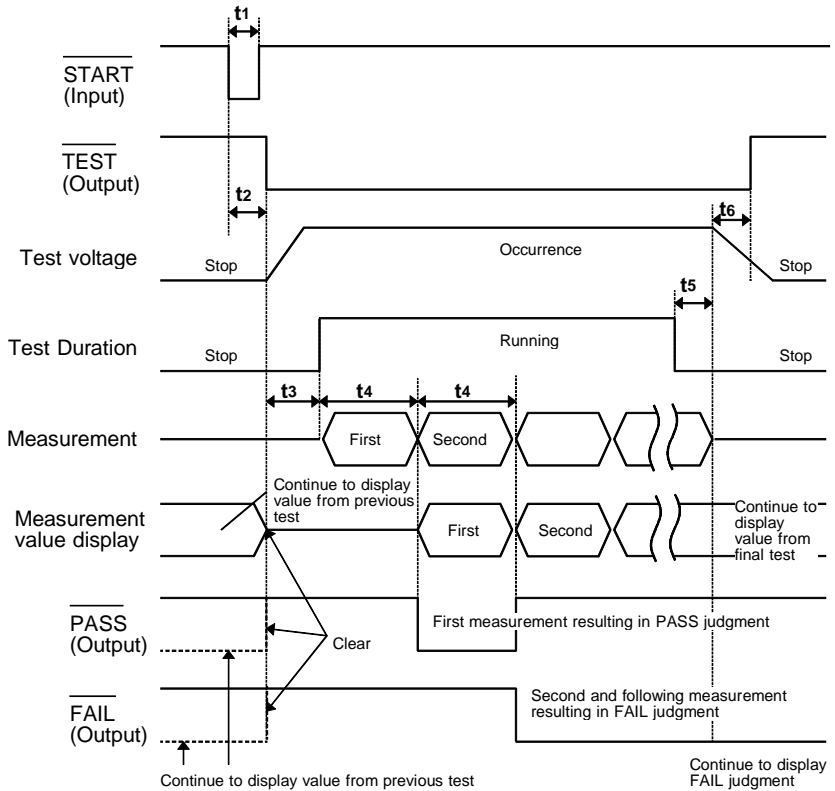

Timing		Time
t1	START signal range, STOP signal range	60 ms min.
t2	Between START input and TEST signal output	80 ms max.
t3	Between TEST signal output and measurement starting time	Approx. 250 ms
t4	Sampling time	FAST 0.1 s/SLOW 1 s
t5	Between time when test duration timer stops and time when test voltage starts falling.	Approx. 20 ms
t6	Between time when test voltage stops and time when TEST signal is disengaged.(HIGH) Note: Reference value when measuring pure resistance 10 M	Test voltage:25 V Approx. 150 ms Test voltage:1000 V Approx. 600 ms

6.1.7 Output Signal Connection Example

- (1) When not using INT.DCV, INT.GND, EXT.DCV terminals

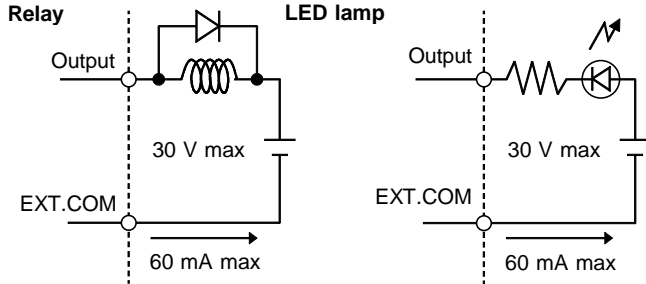

NOTE

When using relay, be sure to install back electromotive force absorption diode.

- (2) When using EXT.DCV, EXT.COM terminals, HIGH (5 to 30 VDC), LOW signals are available.

Connecting negative logic output

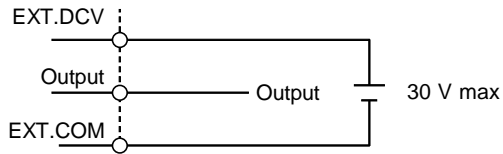

- (3) When using INT.DCV and EXT.DCV, INT.GND and EXT.COM both in short circuit, HIGH (5 VDC), LOW signals are available.

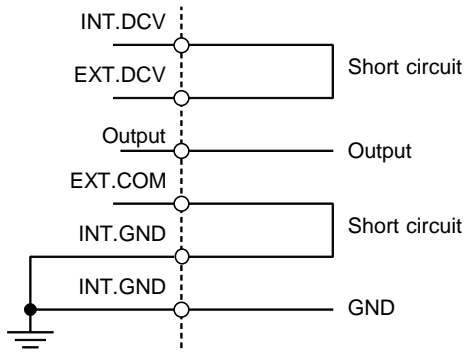

6.2 Analog Outputting



CAUTION

To avoid risk of damaging the unit and output cord, do not input external voltage and current to analog output terminal. Do not connect output cord plug to the 3154 measurement terminal.

Rear panel analog output terminal outputs direct voltage proportional to resistance.

When connecting to recorder, etc., use input resistance over 1 M Ω . Low input resistance results in incorrect readings.

Connect optional 9094 OUTPUT CORD shown below.

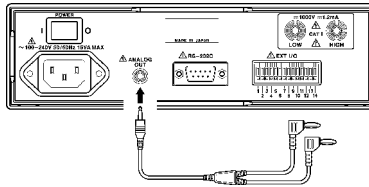

Regardless of selecting auto range or manual range, resistance display value in relation to output voltage is shown in the chart below. When 0.000 M Ω is displayed 0 V is output. Outputs voltage proportional to resistance until maximum value is displayed in each test voltage measurement resistance range outputting 4 VDC.

Test voltage	Resistance display value	Output voltage (DC)
25 V, 50 V	0 M Ω to 200 M Ω	0 V to 4 V
100 V, 250 V, 500 V	0 M Ω to 2000 M Ω	0 V to 4 V
1000 V	0 M Ω to 4000 M Ω	0 V to 4 V
All test voltages	O.F.	4 V
	U.F.	0 V

During testing, analog output follows the 3154 measurement display timing. After completing testing, analog output continues to output and hold final voltage.

6.3 Outputting to Printer

Use optional 9442 PRINTER, 9444 CONNECTION CABLE, 9443 AC ADAPTER and 1196 RECORDING PAPER to print measurement values and judgments result after completing testing.

9442 PRINTER

DPU-414 by SEIKO Electronic Industry, Co.

9443-01 AC ADAPTER

PW-4007-J1 for Japan use by SEIKO Electronic Industry, Co.

9443-02 AC ADAPTER

PW-4007-E1 for Europe use by SEIKO Electronic Industry, Co.

9443-03 AC ADAPTER

PW-4007-U1 for US use by SEIKO Electronic Industry, Co.

■ 3154 Interface Setting

Set 3154 interface setting to "Print" to use RS-232C Interface for printing.

- (1) During READY status, press SHIFT key and then press and hold VOLT key approximately two seconds or longer to display "SPECIAL".

MEASURE	COMPARATOR	TIMER	VOLTAGE
SAMPLING		DELAY	1000V
SPECIAL	SPECIAL		500V
MΩ	MΩ	s	250V
			100V
			50V
			25V

- (2) Press ▲/▼ key to display "rS-232C".

MEASURE	COMPARATOR	TIMER	VOLTAGE
SAMPLING		DELAY	1000V
rS-232C	rS-232C		500V
MΩ	MΩ	s	250V
			100V
			50V
			25V

- (3) Press STOP key to show "rS PC" or "rS Print" blinking. ("rS" does not blink.)

MEASURE	COMPARATOR	TIMER	VOLTAGE
SAMPLING		DELAY	1000V
rS	Print		500V
MΩ	MΩ	s	250V
			100V
			50V
			25V

- (4) Press ▲/▼ key and select "Print". Pressing STOP key confirms setting and returns to READY status.

■ **Verifying Interface**

Just to verify settings, go to setting display to set RS-232C Interface described above. After verifying blinking indicator, press STOP key to return to READY status.

■ Setting 9442 Printer (DIP SW setting)

To enable 9442 for printing with 3154, modify 9442 software DIP SW setting.

- (1) Turn 9442 power off.
- (2) Press and hold down ON LINE switch to power on until starting to print current settings.
- (3) When asked "Continue?:Push'On-line SW'", "Write?:Push'Paper feed SW'" at the end of printing, press ON LINE switch to modify setting.
- (4) Prints "DIP SW-1" and goes to software DIP SW1 setting status. Configure DIP SW1 switches from number 1 through 8 in order described in the chart below.

Select and set in the chart to configure for 3154.

Software DIP SW1

Switch number	Function	ON (ON LINE)	OFF (FEED)
1	Input setting	Parallel	Serial
2	Printing speed	High	Low
3	Auto loading	Valid	Invalid
4	Function	Line feed return	Return
5	Setting command	Valid	Invalid
6	Printing dark to light (set at 100 %)		OFF
7		ON	
8		ON	

To turn ON, press ON LINE switch once. To turn OFF, press FEED switch once. Each switch press prints configuration for verification. To correct configuration, set and configure as instructed in (1) to (4).

After completing setting switch 8, "Continue?:Push'On-line SW'", "Write?:Push'Paper feed SW'" is displayed again.

- (5) Apply same as instructed in (3) and (4) to configure DIP SW2, DIP SW3 switches from 1 through 8.

Software DIP SW2

Switch number	Function	ON (ON LINE)	OFF (FEED)
1	Print mode	Normal (40 lines)	Small (80 lines)
2	User defined words back up	Valid	Invalid
3	Character type	Normal	Special
4	Character 0	0	∅
5	International characters (Only when all four switches are set to OFF, setting results in NG. Any other combination is valid.)	ON	
6		ON	
7		ON	
8		ON	

Software DIP SW3

Switch number	Function	ON (ON LINE)	OFF (FEED)
1	Data bit length	8 Bit	7 Bit
2	Parity	No	Yes
3	Parity setting	Odd	Even
4	Control flow	H/W BUSY	XON/XOFF
5	Baud rate (Set at 19200 bps)		OFF
6		ON	
7		ON	
8			OFF

- (6) After setting DIP SW3 switch 8, press either ON-LINE or FEED switch to complete setting and prints "DIP SW setting complete!!".

NOTE

- 9442 PRINTER factory setting condition is set to connect HIOKI 3166 CLAMP ON POWER HiTESTER. Be sure to configure software DIP SW setting for 9442 PRINTER.
- For printer operation, read 9442 PRINTER instruction manual.
- Use 1196 RECORDING PAPER (thermal paper, 10 rolls) or similar products.

6.3.1 Connecting Printer



To avoid risk of electric shock and damaging equipment, Turn off power supply on the unit and printer before connecting and disconnecting printer and cables.

- (1) Set 3154 and printer.
- (2) Turn OFF both 3154 and printer power.
- (3) Connect 9444 CONNECTION CABLE to 3154 RS-232C connector and printer connector labeled SERIAL.
- (4) After connecting cable, turn ON 3154 and printer power.
- (5) After completing testing, the final measurement data is output to printer.

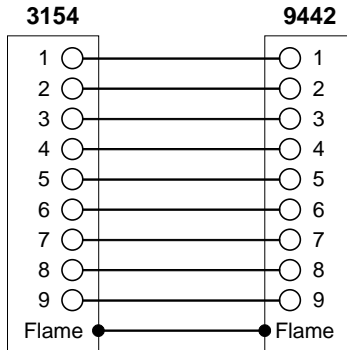

6.3.2 Printing Example

After completing testing, the final measurement data is output to printer.

Printed measurement data is data number, measurement value, judgment results are from left to right.

First measurement data printed after 3154 power is turned on becomes data number 1 and as more tests follow, numbers increase accordingly. After maximum data assigned number 65535 is reached, it starts from number 1 again.

To print data as data number 1, turn OFF 3154 power and then turn back ON.

(1) Example of normal measurement

1	3820	Mohm
2	15.00	Mohm
3	O.F.	Mohm

(2) Example of measurement when comparator is executed.

1	3800	Mohm	PASS
2	15.00	Mohm	FAIL
3	15.00	Mohm	DELAY (*)

(*) : When delay time timer is on, PASS/FAIL judgment is not executed. When test is canceled in the middle of measurement by STOP key, etc., DELAY is printed as judgment result.

Chapter 7

RS-232C Interface

RS-232C Interface enables all 3154 controls except 3154 power switch.
It also performs measurement data transfer independent from other functions.

7.1 Controlling from Personal Computer

3154 RS-232C settings are configured as follows and cannot be modified. Modify and adjust personal computer settings.

Transmission mode	Start-stop synchronization, full duplex
Transfer rate	9600 bps
Data length	8 bit
Parity	None
Stop bit	1 bit
Hand shake	No X flow, hardware flow control
Delimiter	CR, CR + LF for reception CR + LF for transmission

Electric specifications

Input voltage level	5 V to 15 V	ON
	-15 V to -5 V	OFF
Output voltage level (Load resistance 3 to 7 k Ω)	5 V to 9 V	ON
	-9 V to -5 V	OFF

3154 RS-232C connector signal lead is set as follows.

Other pins are not in use.

Interface connector: D-sub 9 pin, male

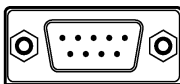

Pin	Signal	IN/OUT	Purpose
2	RxD	IN	Receiving data
3	TxD	OUT	Sending data
5	GND	GND	Signal grounding
Do not use other pins.			

7.1.1 Preparing for Data Transfer



CAUTION

- To avoid risk of electric shock and damaging equipment, turn OFF equipment power before connecting and disconnecting RS-232C Interface connectors.
- To avoid risk of damaging the unit, do not short circuit connectors and output components and do not input voltage.

■ Connecting Connection Cables

Use 9637 RS-232C CABLE or 9638 RS-232C CABLE to connect with personal computer.

When using any other cables, choose a cross cable that allows sending data and receiving data and is connected with signal lead ground lead .

No other particular wiring is required.

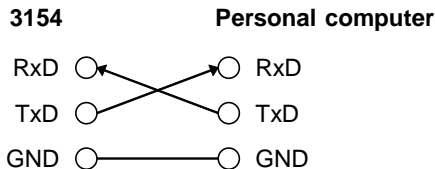

Cable connector on the unit Wiring: Reverse wiring

When connecting with PC/AT compatible computers: 9637 RS-232C CABLE

When connecting with NEC PC 98 series: 9638 RS-232C CABLE

■ Connecting 3154 and Personal Computer

- (1) Use cable to connect 3154 and personal computer.
- (2) After connecting, turn on both 3154 and personal computer power.
- (3) Set RS-232C in personal computer.
 - Set hardware flow OFF in personal computer flow control setting.
 - For settings, see individual software instruction manual.

■ 3154 Interface Setting

Designate 3154 Interface setting "PC" to enable 3154 Interface to communicate with personal computer.

- (1) During READY status, press SHIFT key and then press and hold VOLT key approximately two seconds or longer to display "SPECIAL".

MEASURE	COMPARATOR	TIMER	VOLTAGE
SAMPLING SPECIAL MΩ	COMPARATOR SPECIAL MΩ	TIMER DELAY s	VOLTAGE 1000V 500V 250V 100V 50V 25V

- (2) Press ▲/▼ key to display "rS-232C".

MEASURE	COMPARATOR	TIMER	VOLTAGE
SAMPLING rS-232C MΩ	COMPARATOR rS-232C MΩ	TIMER DELAY s	VOLTAGE 1000V 500V 250V 100V 50V 25V

- (3) Press STOP key to show "rS PC" or "rS Print" blinking. ("rS" does not blink.)

MEASURE	COMPARATOR	TIMER	VOLTAGE
SAMPLING rS MΩ	COMPARATOR PC MΩ	TIMER DELAY s	VOLTAGE 1000V 500V 250V 100V 50V 25V

- (4) Press ▲/▼ key and select "PC". Pressing STOP key confirms setting and returns to READY status.

■ Verifying Interface

To verify setting, just go to setting display to set RS-232C Interface as described above. After verifying blinking indicator, press STOP key to return to READY status.

7.1.2 Communication

Command is sent out from personal computer to 3154. After receiving command, 3154 processes operation according to the command.

When personal computer sends inquiry command (command with "?"), 3154 sends back corresponding response.

During communication, 3154 front panel REMOTE lamp is turned on in remote status.

Remote status disables all operations except STOP key, LOCK key and 9299 SWITCHED PROBE switch operations.

Press LOCK key to disengage remote status (communication) and returns to local status.

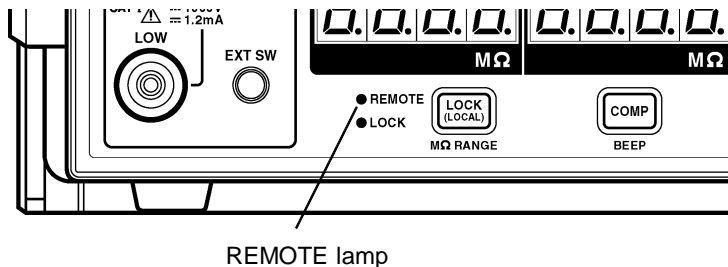

Output Queue

Response messages accumulated in the output queue and are transmitted as data and cleared. The output queue is also cleared when the power is turned off and turned on again. The 3154 has an output queue of 256 bytes capacity. If the response messages overflow this limit of 256 bytes, a query error is generated, and the output queue is cleared.

Input Buffer

The 3154 has an input buffer of 256 bytes capacity. When more than 256 bytes of data are transmitted, when the buffer is full any subsequent bytes received will be ignored.

7.1.3 Command Format

Command Format

The 3154 commands have the following structure.

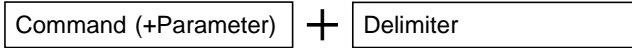

The command and the parameter are separated by "_" (one character space)

If there is no parameter, send the delimiter after the command.

The command may consist of both upper and lower case letters.

Make sure to use one character space as the separator between the command and the parameter.

When the command contains a parameter

":VOLTage_100" (+delimiter)

the command format consists of the command ":VOLTage" followed by the separator "_". Then follows the parameter "100". Following the parameter comes the delimiter

When the command contains no parameter

":STOP" (+delimiter)

the command format consists of the command ":STOP" immediately followed by the delimiter.

NOTE

The meaning of the delimiter is to separate commands and data. When the 3154 receives the delimiter, it starts analysis of the command.

A command can abbreviated. The whole command form is referred to as the "long form" and the abbreviated form as the "short form."

Although the short form is printed in upper case letters and the rest in lower case letters in this instruction manual,

sending command (including parameter and delimiter) from personal computer in either upper or lower case letters is valid.

All responses returned from the 3154 are in upper case letters.

VOLTage OK (the long form)

VOLT OK (the short form)

VOLTA,VOL error

Command/Parameter/Delimiter

There are three types of command.

- A command consisting of a single word beginning with a letter.
Examples: ":VOLTage" etc.
- A command consisting of a sequence of words separated by colons.
Examples: ":BEEPer:KEY",":MOHM:RANGe" etc.
- A command beginning with an asterisk (*) to indicate that is a particular command.
Examples: "*RST" etc.

Command ON/OFF

Some response commands are set with command setting ON/OFF.

Use "HEADer" command to designate setting.

The below is an example of the response command ON and command OFF.

Example: Response when test voltage is set at 1000 V.

Query: ":VOLTage?"

(Command querying current test voltage)

Response: (Test voltage is 1000 V.)

When command is set to ON (command + parameter)

":VOLTage__1000"

When command is set to OFF (only parameter)

"1000"

Parameter

Character data and decimal data are used as the 3154 parameter (data) and the command determines the type of data.

The 3154 uses character string data and numeric data, and the type use varies according to the command in question.

(1) Character data

Character string data must always begin with an alphabetic character, and the characters following can be either alphabetic characters or numerals. Although in character data either upper case letters or lower case letters are accepted, response message output by the 3154 are always in upper case letters.

Example: "200M"

(2) Decimal data

The numeric data values are all represented in decimal, in three formats identified as NR1, NR2 and NR3, and each of these can appear as either a signed number or an unsigned number. Unsigned numbers are taken as positive.

NR1 format: Integer data

Example: +12, -23, 34

NR2 format: Fixed point number

Example: +1.23, -23.45, 3.456

NR3 format: Floating point number

Example: +1E-2, -2.3E+4

The term "NRf format" includes all these three formats.

Each 3154 command designates a format.

Delimiter

Depending on transmission direction, the delimiter is as follows.

From computer to 3154: CR or CR + LF

From 3154 to computer: CR + LF

Separators

(1) Command unit separator

Multiple commands can be written in a line by connecting them with a semicolon";".

Example: ":VOLTage_1000::RANGe_AUTO;*IDN?"

Multiple query commands can also be in a line.

Response is returned in a line with each responding data separated by a semicolon";". Writing multiple commands without inserting semicolons results in text error failing to complete command execution.

(2) Separator between command and parameter

Use space"_" in command with both command and parameter to separate command and parameter.

Example: ":VOLTage_1000"

(3) Parameter • separator

Command with multiple parameters must be separated with comma", " between parameters.

Example: ":COMParator_25,123.4E+06,FAILstop"

7.1.4 Numeric Format Chart

Measurement value

Range	Measurement value	Note
2 M Ω	0.000E+06 to 2.000E+06	4 digits and decimal point
20 M Ω	1.90E+06 to 9.99E+06	3 digits and decimal point
	10.00E+06 to 20.00E+06	4 digits and decimal point
200 M Ω	19.0E+06 to 99.9E+06	3 digits and decimal point
	100.0E+06 to 200.0E+06	4 digits and decimal point
2000(4000) M Ω	190E+06 to 999E+06 1000E+06 to 4000E+06	3 digits 4 digits
Overflow	9999E+06	4 digits
Underflow	0000E+06	4 digits

Lower Limit Value

Range	Lower limit value	Note
2 M Ω max.	0.000E+06 to 2.000E+06	4 digits and decimal point
20 M Ω max.	2.01E+06 to 9.99E+06	3 digits and decimal point
	10.00E+06 to 20.00E+06	4 digits and decimal point
200 M Ω max.	20.1E+06 to 99.9E+06	3 digits and decimal point
	100.0E+06 to 200.0E+06	4 digits and decimal point
Over 200 M Ω	201E+06 to 999E+06 1000E+06 to 4000E+06	3 digits 4 digits

Test Duration / Delay time

0 to 9.9 s	0.0 to 9.9	2 digits and decimal point
10 to 99 s	10 to 99	2 digits

Note: Test duration timer does not apply numeric value data between 0.1 to 0.4.

7.1.5 Command Reference

Format of command explanations

Syntax	Specifies the syntax for the command.
<data>	For a command that has parameters, specifies their format.
Response	Explains the received data.
Error	Specifies what types of error may occur.
Example	These are simple example of the use of the command. PC> Denotes command from the computer. 3154> Denotes command from the 3154.

NOTE

A space is represented by "_" in the examples.

Command List Chart

	Command	Function
Specialized command	*CLS	Clears event • resistor
	*ESR?	Queries event • status • resistor
	*IDN?	Queries equipment ID
	*RST	Resets equipment
Voltage setting	:VOLTage	Sets test voltage
	:VOLTage?	Queries test voltage
Comparator	:COMParator	Sets comparator
	:COMParator?	Queries comparator
	:COMParator:BEEPer	Sets judgment time beep sound
	:COMParator:BEEPer?	Queries judgment time beep sound
Timer	:TIMer	Sets test duration
	:TIMer?	Queries test duration
	:DELay	Sets delay time
	:DELay?	Queries delay time
Resistance range	:MOHM:RANGe	Sets resistance range
	:MOHM:RANGe?	Queries resistance range
Sampling rate	:SPEed	Sets measurement speed
	:SPEed?	Queries measurement speed

	Command	Function
Beep sound during key press	:KEY:BEEPer	Sets beep sound during key press
	:KEY:BEEPer?	Queries beep sound during key press
Save/Load	:SAVE	Saves test conditions
	:SAVE?	Queries if condition saved with designated number is to be saved
	:LOAD	Loads test conditions
9299 SWITCHED PROBE operation	:PROBe	Sets Push Switch probe mode
	:PROBe?	Queries Push Switch probe mode
TEST signal OFF timing	:IO:SIGNal	Sets TEST signal OFF timing
	:IO:SIGNal?	Queries TEST signal OFF timing
Test	:STARt	Starts testing
	:STOP	Ends testing
	:STATe?	Queries testing status
Measurement result	:MEASure?	Queries measurement value
	:MEASure:COMParator?	Queries judgment result
	:MEASure:RESult?	Queries measurement value, judgment result
Command ON/OFF function	:HEADer	Sets responding command ON/OFF
	:HEADer?	Queries responding command ON/OFF

***CLS**

Clears event status register(ESR) status.

Syntax *CLS

***ESR?**

Returns the value of event status register (ESR) as decimal notation numerical value in NR1 format 0 to 7 and then clears event status register status. Response is parameter only. Register is configured as shown in the chart below. When error occurs, it returns data as numeric value calculated in decimal notation based on each error.

Syntax *ESR?

Response <data> 0 to 7 (NR1 numeric data)

Example PC>"*ESR?" 3154>"7"
bit0(Command error),bit1(Execute error),bit2(Query error)
All set as 1.

Event status register

Decimal notation	-	-	-	-	-	4	2	1
Bit	bit7	bit6	bit5	bit4	bit3	bit2	bit1	bit0
Status	Not in use	Not in use	Not in use	Not in use	Not in use	QYE	EXE	CME

QYE: Query error EXE: Execute error CME: Command error

***IDN?**

Queries manufacturer's name, model name, and software version. Response is parameter only.

First field :Manufacturer's name

Second field :Model name

Third field :Serial number (not used, 0 at all times)

Fourth field :Software version

Syntax *IDN?

Response <data>

Example PC>"*IDN?"
3154>"HIOKI,3154,0,V1.00"

***RST**

Resets 3154 setting. Execute *RST to stop testing and reset setting by clearing all saved test conditions. See 5.4 to reset setting.

Syntax *RST

Example Execute resetting PC>"*RST"

:VOLTage

Sets test voltage

Syntax :VOLTage_<data>

<data> Test voltage 25/50/100/250/500/1000 (NR1 numeric data)

Example Sets test voltage at 100 V. PC>":VOLTage_100"

:VOLTage?

Queries test voltage. Returns in NR1 numeric data (<data>).

Syntax :VOLTage?

Response :VOLTAGE_<data> or simply<data>

<data> Test voltage 25/50/100/250/500/1000 (NR1 numeric data)

Example Queries test voltage PC>":VOLTage?"
 Test voltage is 100 V.
 3154> When command ON ":VOLTage_100"
 When command OFF "1000"

:COMParator

Sets comparator lower limit value and test mode. Whereas key press sets only predetermined values, this command enables setting lower limit value at any value. Lower limit value at each test voltage is stored. To set comparator to function off, select OFF. After setting comparator, set resistance range. See 3.3.

Syntax :COMParator_<data1>,<data2>,<data3>

<data1> Test voltage 25/50/100/250/500/1000 (NR1 numeric data)

<data2> Comparator lower limit value OFF (character data) or NR3 numeric data (See 7.1.4 Numeric Format Chart)

<data3> Test mode OFF/CONTInue/FAILstop

Example 1 To set comparator lower limit value 123.4 M at 25 V and test mode as FAIL STOP
 PC>":COMParator_25,123.4E+06,FAILstop"

Example 2 To set comparator function OFF at 1000 V
 PC>":COMParator_1000,OFF,OFF"

Error Setting value out of measurement range at each test voltage results in execute error.

:COMParator?

Queries lower limit value and test mode.

Lower limit value is returned in text data and NR3 numeric data (<data2>). Test mode is returned as text data. Command is not included in response. Lower limit value and test mode at each test voltage are stored.

When set without comparator, returns "OFF,OFF".

Syntax :COMParator?_<data1>

<data1> Test voltage 25/50/100/250/500/1000 (NR1 numeric data)

Response <data2>,<data3>

<data2> Comparator lower limit value OFF(character data) or NR3 numeric data (See 7.1.4 Numeric Format Chart)

<data3> Test mode OFF/CONTINUE/FAILSTOP

Example 1 To query comparator lower limit value at 25 V and test mode
 PC>":COMParator?_25"
 Lower limit value at 25 V is 123.4 M and test mode is FAILSTOP.
 3154>"123.4E+06,FAILSTOP"

Example 2 To query comparator lower limit value at 1000 V and test mode.
 PC>":COMParator?_1000"
 At 1000 V, comparator is OFF.
 3154>"OFF,OFF"

:COMParator:BEEPer

Sets beep sound at comparator judgment and at the end of timed duration.

Syntax :COMParator:BEEPer_<data>

<data> PASS/FAIL/OFF/END

Example To set to beep at FAIL judgment.
 PC>":COMParator:BEEPer_FAIL"

:COMParator:BEEPer?

Queries beep sound settings at comparator judgment and at the end of timed duration. Returns setting in text data(<data>).

Syntax :COMParator:BEEPer?

Response :COMParator:BEEPER_<data> or simply<data>

<data> PASS/FAIL/OFF/END

Example To query beep sound during judgment
 PC>":COMParator:BEEPer?"
 Beeps at FAIL judgment
 3154> When command ON ":COMPARATOR:BEEPER_FAIL"
 When command OFF "FAIL"

:TiMer

Sets test duration. 0.0 is set when test duration is not set. If during testing, it stops testing and sets test duration.

Syntax :TiMer_<data>

<data> Test duration(unit:second) 0.0, 0.5 to 9.9, 10 to 99 (NR2 numeric data) (See 7.1.4 Numeric Format Chart)

Example To set 10 seconds as test duration.
PC>":TiMer_10"

:TiMer?

Queries test duration setting.
Returns test duration in NR2 numeric data (<data>). Returns 0.0 when test duration timer is not in use.

Syntax :TiMer?

Response :TiMer_<data> or simply<data>
Test duration(unit:second) 0.0, 0.5 to 9.9, 10 to 99 (NR2 numeric data) (See 7.1.4 Numeric Format Chart)

Example To query test duration setting PC>":TiMer?"
Test duration is 10 seconds.
3154> When command ON ":TiMer_10"
When command OFF "10"

:DELaY

Sets delay time. If during testing, it stops test and sets delay time.

Syntax :DELaY_<data>

<data> Delay time(unit:second) 0.0 to 9.9, 10 to 99 (NR2 numeric data) (See 7.1.4 Numeric Format Chart)

Example To set 5.5 seconds as delay time. PC>":DELaY_5.5"

:DELaY?

Queries delay time. Returns delay time in NR2 numeric data (<data>).

Syntax :DELaY?

Response :DELaY_<data> or simply<data>

<data> Delay time(unit:second) 0.0 to 9.9, 10 to 99 (NR2 numeric data) (See 7.1.4 Numeric Format Chart)

Example To query delay time PC>":DELaY?"
Delay time is 5.5 seconds.
3154> When command ON ":DELaY_5.5"
When command OFF "5.5"

:MOHM:RANGe

Sets resistance range.

Syntax :MOHM:RANGe_<data>

<data> 2M/20M/200M/2000M/4000M/AUTO

Example To set at 200 M .
PC>":MOHM:RANGe_200M"

Error Setting at 2000 M when test voltage is 25 V or 50 V results in execute error.

:MOHM:RANGe?

Queries resistance range. Returns resistance range in text data.

Syntax :MOHM:RANGe?

Response :MOHM:RANGe_<data> or simply<data>

<data> 2M/20M/200M/2000M/4000M/AUTO

Example To query resistance range PC>":MOHM:RANGe?"
Resistance range is 200 M .
3154> When command ON "":MOHM:RANGe_200M"
When command OFF "200M"

:KEY:BEEPer

Sets beep sound ON/OFF during key press.

Syntax :KEY:BEEPer_<data>

<data> ON/OFF

Example To set to beep during key press PC>":KEY:BEEPer_ON"

:KEY:BEEPer?

Queries beep sound ON/OFF setting during key press.
Returns ON/OFF setting in text data.

Syntax :KEY:BEEPer?

Response :KEY:BEEPer_<data> or simply<data>

<data> ON/OFF

Example To query beep sound ON/OFF setting during key press
PC>":KEY:BEEPer?"
Set to ON 3154> When command ON "":KEY:BEEPER_ON"
When command OFF "ON"

:SPEEd

Sets sampling rate to FAST/SLOW.

Syntax :SPEEd_<data>

<data> FAST/SLOW

Example To set sampling rate to FAST PC>":SPEEd_FAST"

:SPEEd?

Queries sampling rate. Returns measurement speed setting FAST/SLOW in text data.

Syntax :SPEEd?

Response SPEED_<data> or simply<data>

<data> FAST/SLOW

Example To query sampling rate PC>":SPEEd?"
Sampling rate is set with FAST.
3154> When command ON ":SPEED_FAST"
When command OFF "FAST"

:SAVE

Saves test condition with designated number.

Syntax :SAVE_<data>

<data> 1 to 10(NR1 numeric data)

Example To save as No. 3 PC>":SAVE_3"

:SAVE?

Queries if test condition is saved with designated number. Returns setting in numeric data (<data2>). Command is not included in response.

Syntax :SAVE?_<data1>

<data1> Test condition numbers 1 to 10 (NR1 numeric data)

Response <data2>

<data2> 0 to 1 (NR1 numeric data)
1: Test condition is saved.
0: Test condition is not saved.

Example To query if saved as No. 3 PC>":SAVE?_3"
Saved as No. 3. 3154>"1"

:LOAD

Loads designated test condition. If during testing, it stops testing and loads test condition.

Syntax :LOAD_<data>

<data> Test condition numbers 1 to 10 (NR1 numeric data)

Example To load No. 3 test condition PC>"LOAD_3"

:PROBe

Sets 9299 SWITCHED PROBE mode. If during testing, it stops testing and sets mode.

Syntax :PROBe_<data>

<data> CONTInue/TRIGger
CONTInue : Continue mode
TRIGger : Trigger mode

Example To set continue mode PC>":PROBe_CONTInue"

:PROBe?

Queries 9299 SWITCHED PROBE mode setting. Returns CONTINUE or TRIGGER setting in text data.

Syntax :PROBe?

Response :PROBe_<data> or simply<data>

<data> CONTINUE/TRIGGER
CONTInue: Continue mode
TRIGger: Trigger mode

Example To query probe mode PC>":PROBe?"
Continue mode is set for probe mode setting.
3154> When command ON ":PROBE_CONTINUE"
When command OFF "CONTINUE"

:IO:SIGNal

Sets timing for TEST signal to return from LOW to HIGH when test is complete.

Syntax :IO:SIGNal_<data>

<data> SLOW/FAST

Example To set to FAST for timing. PC>":IO:SIGNal_FAST"

:IO:SIGNal?

Queries timing for TEST signal to return from LOW to HIGH when test is complete. Returns setting with SLOW or FAST.

Syntax :IO:SIGNal?

Response :IO:SIGNal_<data> or simply<data>

<data> SLOW/FAST

Example To query timing PC>":IO:SIGNal?"
FAST is set for timing.
3154> When command ON ":IO:SIGNal_FAST"
When command OFF "FAST"

:START

Starts testing.

Syntax :START

Example PC>"START"

Error Executing this command during testing results in execute error.

:STOP

Stops testing.

Syntax :STOP

Example PC>":STOP"

:STATe?

Returns 3154 status in numeric data (<data>). Command is not included in response.

Syntax :STATe?

Response <data>

<data> 0 to 2(NR1 numeric data)
0: Stopped 1: Testing 2: Discharging

Example To query status PC>":STATe?"
During testing 3154>"1"

:MEASure?

Queries measurement value. Returns measurement value at time of receiving this command in NR3 numeric value data. When 3154 is in READY status, it returns final measurement value when previous test was completed.

Syntax :MEASure?

Response :MEASURE_<data> or simply<data>

<data> Measurement value (See 7.1.4 Numeric Format Chart)

Example To query measurement value PC>":MEASure?"
 Measurement value is 123.4 MΩ.
 3154> When command ON "MEASURE_123.4E+06"
 When command OFF "123.4E+06"

:MEASure:COMParator?

Queries judgment result. Returns judgment result at time of receiving this command in text data. When comparator function is OFF, "PASS" is returned at all times as judgment result. Returns "DELAY" when delay time timer is ON. During READY status, it returns final judgment result when previous test was completed.

Syntax :MEASure:COMParator?

Response :MEASure:COMPARATOR_<data> or simply<data>

<data> Measurement result PASS/FAIL/DELAY

Example To query judgment result PC>":MEASURE:COMParator?"
 Judgment result is PASS.
 3154> When command ON ":MEASURE:COMPARATOR_PASS"
 When command OFF "PASS"

:MEASure:RESult?

Queries measurement value and judgment result. After completing test, it returns measurement value and then judgment result as <measurement value> <judgment result> in data (<data1>,<data2>). When 3154 is in READY status, it returns final measurement value and judgment result when previous test was completed.

When this command is accepted, it does not proceed with the following command analysis until after test is complete and response data is returned. When this command is sent, the test cannot be canceled with STOP command.

Syntax :MEASure:RESult?

Response :MEASURE:RESULT_<data1>,<data2> or <data1>,<data2>

<data1> Measurement value (See 7.1.4 Numeric Format Chart)

<data2> Judgment result PASS/FAIL/DELAY

Example To query measurement value and judgment result
 PC>":MEASure:RESult?"
 Measurement value is 123.4 MΩ, judgment result is PASS.
 3154> When command ON
 ":MEASURE:RESULT_123.4E+06,PASS"
 When command OFF
 "123.4E+06,PASS"

:HEADer

Sets response with or without command. When powered on, it resets to OFF.

Syntax :HEADer_<data>

<data> ON/OFF
 ON :With command OFF:Without command

Example To set response with command
 PC>":HEADer_ON"

:HEADer?

Queries response setting with or without command. Returns ON/OFF setting in text data (<data>).

Syntax :HEADer?

Response :HEADER_<data> or simply<data>

<data> ON/OFF
 ON :With command OFF:Without command

Example To query response setting with or without command
 PC>"HEADer?"
 3154> When command ON "::HEADER_ON"
 When command OFF "OFF"

7.2 Sending Measurement Data to PC

RS-232C Interface enables to send measurement data to personal computer. Transferable measurement data includes final measurement value and judgment result at time of completing test. Measurement data cannot be sent at each measurement (sampling). 3154 cannot be controlled from personal computer.

Specifications for data transfer

Transmission mode	Start-stop synchronization, full duplex
Transfer rate	19200 bps
Data length	8 bit
Parity	None
Stop bit	1 bit
Hand shake	No X flow, hardware flow control

■ Preparation for communication

Connect as instructed in 7.1.1.

■ 3154 Interface Setting

To use 3154 RS-232C Interface to enable measurement data transfer, set interface setting to "Print".

- (1) During READY status, press SHIFT key and then press and hold VOLT key for approximately two seconds or longer to display "SPECIAL".

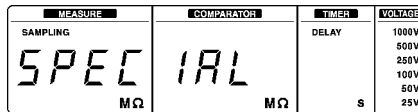

- (2) Press ▲/▼ key to display "rS-232C".



- (3) Press STOP key to show "rS PC" or "rS Print" blinking. ("rS" does not blink.)

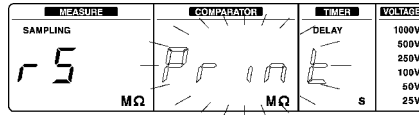

- (4) Press ▲/▼ key and select "Print". Pressing STOP key confirms setting and returns to READY status.

■ Verifying Interface

Just to verify setting, go to setting display to set RS-232C Interface described above. After verifying blinking indicator, press STOP key to return to READY status. Even when connected with personal computer, set "Print" for data transfer, not "PC".

■ Transferring Data

- (1) Start testing by pressing 3154 START key, etc.
- (2) After completing test, measurement data is transferred.

■ Transferring Data Example

Measurement data to be transferred include from left to right; data number, measurement value, judgment result. First measurement data transferred after 3154 power is turned on becomes data number 1 and as more tests follow, numbers increase accordingly. After maximum assigned data number 65535 is reached it starts from number 1 again.

To transfer data as data number 1, turn OFF 3154 power and then turn back ON.

(1) Example: normal measurement time

1	3820	Mohm
2	15.00	Mohm
3	O.F.	Mohm

(2) Example: when comparator is in use

1	3500	Mohm	PASS
2	15.00	Mohm	FAIL
3	15.00	Mohm	DELAY (*)

*:When delay time timer is on, PASS/FAIL judgment is not executed. When test is canceled in the middle of measurement by STOP key, etc., DELAY is transferred as judgment result.

Chapter 8

Specifications

8.1 General Specifications

Display	LED
Sampling rate	FAST: 10 counts/s SLOW: 1 count/s
Interface	External I/O, RS-232C, Analog output, EXT.SW Analog output accuracy: $\pm 2\%$ f.s. (at display value)
External terminal	Front: Measurement terminal (HIGH,LOW), EXT.SW terminal Rear: Measurement terminal (HIGH,LOW), external I/O terminal, RS-232C connector, analog output terminal Measurement terminal front/rear cannot be changed. Measurement terminals are insulated with a direct current to ground condenser.
Ambient operating conditions	0 to 40°C (32 to 104°F) 80% rh or less (no condensation)
Ambient storage conditions	-10 to 50°C (14 to 122°F) 90 % rh or less (no condensation)
Operating place	Indoor, max.2000 m (6562 feet) height
Power supply	Rated power voltage: 100 to 240 VAC (Voltage fluctuations of 10% from the rated supply voltage are taken into accounts) Rated power frequency: 50/60 Hz
Maximum rated power	15 VA
Dielectric strength	(1) Between the power supply and outer case, the power supply and external terminals, the power supply and protective grounding terminals, the power supply and all measurement terminals: One minute at 1.35 kVAC (2) Between all measurement terminals and protective grounding terminals: One minute at 1.1 kVDC (3) Between EXT I/O terminal and protective grounding terminals, EXT I/O terminal and all measurement terminals: One minute at 500 VAC The above excludes INT.DCV and INT.GND terminals out of EXT I/O terminals.
Over voltage input protection	1100 VDC (positive polarity only) (between measurement terminals HIGH-LOW)

Memory function	Memory: Maximum 10 combinations (save/load able)
Storable content in memory per combination	Test voltage, lower limit, test mode, judgment beep sound, test duration, delay time, resistance range, sampling rate
Data hold	Automatically holds measurement value and judgment result at measurement completion.
Key lock	Available
Automatic discharge function	Warns remaining voltage with blinking TEST lamp
Beep sound	Selectable ON/OFF during key press. Selectable ON/OFF during PASS/FAIL judgment
System reset	Available
Dimensions	215W X 61H X 213D mm (excluding projections) (8.46"W X 2.40"H X 8.39"D)
Mass	Approx. 1.1 kg (38.8 oz)
Accessories	Instruction Manual Grounded three-core power cord
Options	9294 TEST PROBE 9185 TEST LEAD 9299 SWITCHED PROBE 9094 OUTPUT CORD 9637 RS-232C CABLE (9 pin-9 pin/Cross/1.8 m) 9638 RS-232C CABLE (9 pin-25 pin/Cross/1.8 m) 9442 PRINTER 9443-01AC ADAPTER (for Japan) (for printer) 9443-02AC ADAPTER (for Europe) (for printer) 9443-03AC ADAPTER (for US) (for printer) 9444 CONNECTION CORD (for printer) 1196 RECORDING PAPER (for printer)
Standard applying	Safety: EN61010:1993+A2:1995 Power supply: Pollution Degree 2, overvoltage category (anticipated transient overvoltage 2500 V) Measurement terminal: Pollution Degree 2, overvoltage category (anticipated transient overvoltage 330 V)

8.2 Measurement Part Specifications

Measurement method	Applied DC voltage method	
A/D conversion method	Successive approximation comparison method	
Test voltage (rated)	25 VDC	Resistance range: 0 to 200.0 MΩ
	50 VDC	Resistance range: 0 to 200.0 MΩ
	100 VDC	Resistance range: 0 to 2000 MΩ
	250 VDC	Resistance range: 0 to 2000 MΩ
	500 VDC	Resistance range: 0 to 2000 MΩ
	1000 VDC	Resistance range: 0 to 4000 MΩ

Resistance Range Configuration (manual range)

Test voltage (rated)	Resistance range	Maximum display	Resolution
25 V, 50 V	2 MΩ	2.000 MΩ	0.001 MΩ
	20 MΩ	20.00 MΩ	0.01 MΩ
	200 MΩ	200.0 MΩ	0.1 MΩ
100V, 250V, 500V	2 MΩ	2.000 MΩ	0.001 MΩ
	20 MΩ	20.00 MΩ	0.01 MΩ
	200 MΩ	200.0 MΩ	0.1 MΩ
	2000 MΩ	2000 MΩ	1 MΩ*1
1000 V	2 MΩ	2.000 MΩ	0.001 MΩ
	20 MΩ	20.00 MΩ	0.01 MΩ
	200 MΩ	200.0 MΩ	0.1 MΩ
	4000 MΩ	4000 MΩ	1 MΩ*1

*1: To display value over 1000 MΩ, last digit is fixed at 0 and revolving power is 10 MΩ.

When Setting Auto Range

Range Increment: Range increments When 2000 count exceeds current range (except top range).

Range Decrement: Range decrements when 190 counts go below current range (except from 2 M Ω range).

Overflow display: O.F (When exceeding maximum value in resistance measurement range)

When Setting Manual Range

Overflow flow display: O.F when exceeding maximum value in each range.

Underflow display: U.F when going below 190 counts (except from 2 M Ω range).

Accuracy

Conditions of Guaranteed Accuracy	Temperature and humidity range 23 ± 5 ($73 \pm 9^{\circ}\text{F}$), 80% rh or less (no condensation) Warm-up: time 30 minutes
Sampling Rate	Consistent in both FAST/SLOW
Accuracy coefficient	Accuracy specifications X 0.1/ $^{\circ}\text{C}$ At 0 to 18 $^{\circ}\text{C}$ (32 to 64 $^{\circ}\text{F}$), 28 to 40 $^{\circ}\text{C}$ (82 to 104 $^{\circ}\text{F}$)

Test voltage (rated)	Measurement range	Accuracy
25 V	0 to 20.00 M Ω	$\pm 2\%$ rdg. ± 5 dgt.
	19.0 to 200 M Ω	$\pm 5\%$ rdg.
50 V	0 to 20.00 M Ω	$\pm 2\%$ rdg. ± 5 dgt.
	19.0 to 200 M Ω	$\pm 5\%$ rdg.
100 V	0 to 20.00 M Ω	$\pm 2\%$ rdg. ± 5 dgt.
	19.0 to 2000 M Ω	$\pm 5\%$ rdg.
250 V	0 to 100.0 M Ω	$\pm 2\%$ rdg. ± 5 dgt.
	100.1 to 2000 M Ω	$\pm 5\%$ rdg.
500 V	0 to 999 M Ω	$\pm 2\%$ rdg. ± 5 dgt.
	1000 to 2000 M Ω	$\pm 5\%$ rdg.
1000 V	0 to 999 M Ω	$\pm 2\%$ rdg. ± 5 dgt.
	1000 to 4000 M Ω	$\pm 5\%$ rdg.



Limit determined by capacitance contained in equipment to be measured

 : If capacitance contained in equipment to be measured is within range limit illustrated below, display value variance is within $\pm 2\%$ rdg.



 : If capacitance contained in equipment to be measured is within range limit illustrated below, display value variance is within $\pm 5\%$ rdg.

 : Outside measurement range

Sampling rate: FAST

Voltage	Resistance measurement range (unit: M Ω)							
	0	2	20	100	200	1000	2000	4000
25 V	0.5 μ F max.	2 nF max.	5 nF max.	1 nF max.				
50 V	1 μ F max.	5 nF max.	10 nF max.	5 nF max.				
100 V	5 μ F max.	50 nF max.	5 nF max.		1 nF max.			
250 V	5 μ F max.	0.5 μ F max.		0.5 μ F max.	0.1 μ F max.			
500 V	5 μ F max.	0.5 μ F max.			0.1 μ F max.	0.1 μ F max.		
1000 V	5 μ F max.		0.5 μ F max.		0.1 μ F max.	0.1 μ F max.		

Sampling rate: SLOW

Voltage	Resistance measurement range (unit: M Ω)							
	0	2	20	100	200	1000	2000	4000
25 V	10 μ F max.	1 μ F max.	0.5 μ F max.	0.1 μ F max.				
50 V	10 μ F max.	1 μ F max.	0.5 μ F max.	0.1 μ F max.				
100 V	10 μ F max.	5 μ F	0.5 μ F max.	0.1 μ F max.		50 nF max.		
250 V	10 μ F max.		1 μ F max.		0.5 μ F max.	0.1 μ F max.		
500 V	10 μ F max.		1 μ F max.		0.5 μ F max.	0.1 μ F max.		
1000 V	10 μ F max.		1 μ F max.			0.1 μ F max.		

Test Voltage/Measurement Current (in accordance with JIS C 1302-1994 Insulation Resistance Tester)

When resistance below lower limit measurement resistance is measured, voltage between measurement terminals drops. When resistance above lower limit measurement resistance is measured, voltage between measurement terminals becomes 1 to 1.2 times rated value.

Test voltage (rated) Unloaded voltage is 1 to 1.2 times rated value.	Lower limit measurement resistance value capable of holding test voltage rated value	Rated measurement current	Short circuit current
25 V	0.025 MΩ	1 to 1.2 mA	1.2 mA max.
50 V	0.05 MΩ		
100 V	0.1 MΩ		
250 V	0.25 MΩ		
500 V	0.5 MΩ		
1000 V	2 MΩ	0.5 to 0.6 mA	0.6 mA max.

Rated measurement current: Current that can flow when lower limit measurement resistance is measured.

Comparator Specifications

Key press setting	Select lower limit value from designated options.
RS-232C setting	Set optional lower limit value within measurement range.
PASS judgment	Measurement resistance value \geq lower limit value
FAIL judgment	Measurement resistance value $<$ lower limit value
Judgment process	Beep sound, PASS/FAIL display, signal output to external I/O according to each judgment result. (Beep during judgment: Select from PASS, FAIL, and OFF)
Test mode	Continue mode/FAIL STOP mode

Test duration timer specifications

After measurement START is initiated and waiting time (0.35 s max) + designated test duration elapses, timer stops measurement (Settable ON/OFF setting).

When ON is set	Displays countdown time from designated time.
When OFF is set	Displays --, test duration = ∞
Setting range	0.5 to 99 s
Setting resolution	0.1 s (When setting range is 0.5 to 9.9 s) 1 s (When setting range is 10 to 99 s)
Accuracy	± 0.05 s (When setting range is 0.5 to 9.9 s) ± 0.5 s (When setting range is 10 to 99 s)

Delay time timer specifications

After measurement START is initiated and until waiting time (0.35 s max) + designated delay time elapses, it does not start test duration timer countdown time display and comparator judgment. Operates with applied voltage, resistance measurement, display and analog output.

When ON is set	DELAY lamp turns on.
When OFF is set	DELAY lamp turns off. Delay time = 0
Setting range	0.1 to 9.9 s
Setting resolution	0.1 s (When setting range is 0.1 to 9.9 s) 1 s (When setting range is 10 to 99 s)
Accuracy	± 0.05 s (When setting range is 0.1 to 9.9 s) ± 0.5 s (When setting range is 10 to 99 s)

Voltage application duration and timer setting

Voltage application duration = -0 s to +0.5 s in addition to delay time + test duration time.

Synchronized with time from voltage rising point at 50 % to voltage falling point at 50% (measurement resistance 10 M Ω , parallel circuit capacitance under 100 pF)

Response time chart

Response time is determined by time after START signal is input and measurement value reaches within accuracy specifications until comparator judgment result is output to external I/O at each measurement value.

Resistance range	Test voltage	Sampling rate FAST	Sampling rate SLOW
2 / 20 MΩ	All test voltage	0.5 s max.	1.5 s max.
200 MΩ	25 V, 50 V	0.6 s max.	1.5 s max.
	100 to 1000 V	0.5 s max.	1.5 s max.
2000 / 4000 MΩ	100 to 1000 V	0.7 s max.	1.5 s max.
Auto range (Including range change)	25 V, 50 V	2 s max.	5 s max.
	100 to 1000 V	2.5 s max.	6 s max.

Status with Valid/Invalid input

The following chart shows each status with key press, signal and command input valid/invalid.

When valid and invalid occur at the same time depending on combination, it defaults to invalid.

Status \ Input	Key press				9299	External I/O input signal			RS-232C	
	START	STOP (ENTER)	LOCK (LOCAL)	Other	START /STOP	START	STOP	Other	START	Other
When external I/O STOP signal is LOW	invalid	valid	valid	valid	invalid	invalid	-	valid	invalid	valid
Remote status	invalid	valid	valid Disengage remote	invalid	valid	valid	valid	valid	valid	valid
Key lock status	valid	valid	valid Disengage lock	invalid	valid	valid	valid	valid	valid	valid
TEST status	-	valid	invalid	invalid	valid	-	valid	invalid	-	*1

*1: some commands are invalid.

8.3 Dimensions

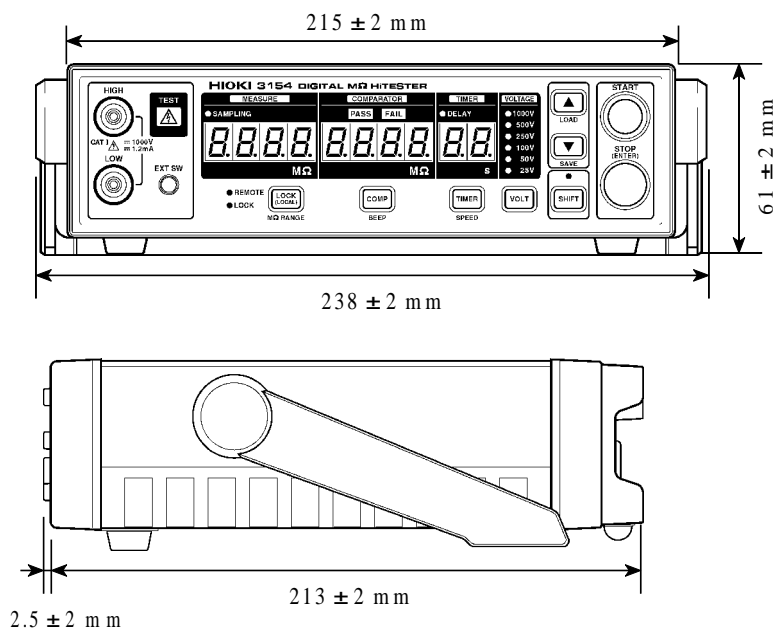

8.4 Options and specifications

9185 TEST LEAD

Both red and black pin shaped probes.

Lead length : approximately 85 cm.

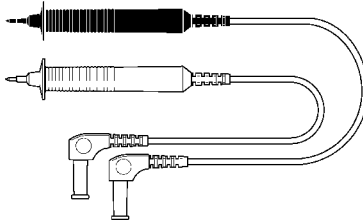

9294 TEST PROBE

Probe in red is pin shaped. Probe in black is clip shaped.

Lead length : approximately 1.2 m.

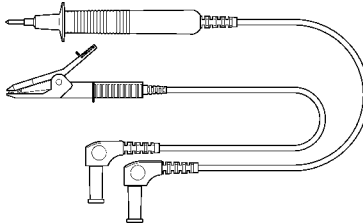

9299 SWITCHED PROBE

To use 9299 SWITCHED PROBE, one more probe is required. Lead length : approximately 80 cm.

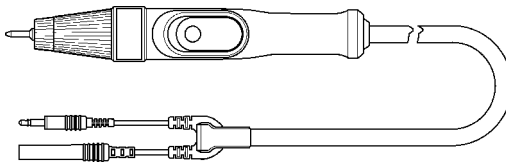

9094 OUTPUT CORD

Used for analog output.

Lead length : approximately 1.5 m.

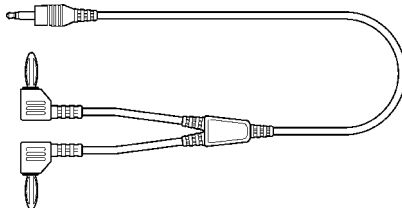
**9442 PRINTER**

To use 9442 Printer, purchase separately sold 9444 CONNECTION CORD and 9443 AC ADAPTER.

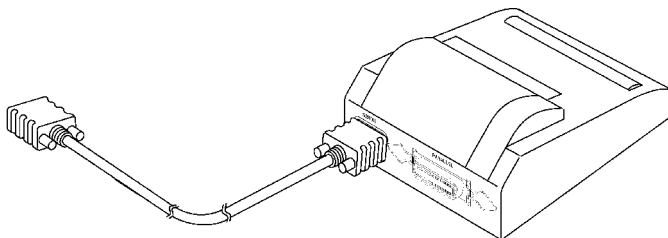

Figure shows 9442 PRINTER connected with 9444 CONNECTION CORD.

Printing method	Thermal serial dot method
Paper width	112 mm
Printing speed	52.5 cps
Power supply	9443 AC ADAPTER or included nickel hydrogen batteries (prints approximately 3000 lines charged with 9443)
Dimensions and mass	160W X 66.5H X 170D mm (6.3"W X 2.6H X 6.7"D) Approx. 580 g (20.5oz.)

Chapter 9

Maintenance and Service

9.1 Maintenance and Inspection

■ **To ensure the safe operation of this unit, perform maintenance regularly.**

- Be sure to read assiduously the various items highlighted in this manual for attention, in order to use the unit correctly.
- If the unit is not functioning properly, check the "Troubleshooting" list. If a problem is found, contact your dealer or HIOKI representative. Pack the unit carefully so that it will not be damaged during transport, and write a detailed description of the problem. HIOKI cannot bear any responsibility for damage that occurs during shipment.
- If the unit has been subject to moisture, or if oil and dust have accumulated in the unit interior, the danger of electrical shock or fires resulting from the deterioration of insulation increases greatly. If the unit is ever subject to excessive moisture, oil, or dust, cease use immediately, and return the unit to us for maintenance
- Periodic calibration is necessary to verify and maintain accuracy. If calibration becomes necessary, return the unit to us for maintenance.
- Spare and replacement parts for this product are guaranteed to be available only until 7 years after manufacture of this model is terminated.

■ Cleaning

Gently wipe dirt from the surface of the unit with a soft cloth moistened with a small amount of water or mild detergent.

Do not try to clean the unit using cleaners containing organic solvents such as benzine, alcohol, acetone, ether, ketones, thinners, or gasoline. They may cause discoloration or damage.

9.2 Trouble shooting

If the unit is not functioning, check the following before calling for service.

Problem	Possible cause and solution
Cannot set test voltage by key press.	<ul style="list-style-type: none"> • Voltage is selected by external I/O VOLT0 to VOLT2. Set VOLT0 to VOLT2 signal input voltage at all LOW or all HIGH, or disconnect all. See 6.1.1.
Cannot use key press.	<ul style="list-style-type: none"> • Key lock is engaged. (See 5.4.) • Communication with RS-232C is occurring. (During communication, key press cannot be used.)
Does not perform comparator judgment with no delay time setting.	<ul style="list-style-type: none"> • Delay time is set instead of test duration. (See 4.3.)
Comparator judgment result is incorrect.	<ul style="list-style-type: none"> • Resistance range is not set at range according to lower limit value.(See 4.2.2) • Probe has broken lead. • Probe is not connected securely. • Probe is connected to both front and rear measurement terminals.
Measurement value is incorrect.	<ul style="list-style-type: none"> • Probe has broken lead. • Probe is not connected securely. • Probe is connected to both front and rear measurement terminals. • Measurement took place immediately after the unit was moved and exposed to significant room temperature difference causing possible condensation.
Switch on 9299 does not function properly.	<ul style="list-style-type: none"> • 9299 signal lead plug is not securely connected. • 9299 is not set properly. (See 5.7.)
Cannot use START.	<ul style="list-style-type: none"> • External I/O STOP signal is set LOW. • STOP key is kept pressed.
RS-232C does not function at all.	<ul style="list-style-type: none"> • Cables are not connected properly. • Power is not turned ON all connected equipment. • Communication conditions are not configured properly. • 3154 Interface is not set properly. (See 7.1.1, 7.2.)

Problem	Possible cause and solution
Display does not illuminate even after turning power ON.	<ul style="list-style-type: none"> • Wiring connected to external I/O INT.DCV terminal is touching INT.GND or external grounding wire.
ERROR 20 TO ERROR 24 is displayed. n0 AdJUSt or n0 dA AdJ is displayed when power is turned on.	<ul style="list-style-type: none"> • Internal EEPROM is damaged. All 3154 settings are stored in internal EEPROM. EEPROM has limit for writing to. When EEPROM reaches limit error is displayed.

For any additional problems or when the cause is not clear, try system reset.

To reset system, see 5.4 System Reset.

If any of the following should occur, stop using the unit, disconnect the power cord, leads and probe, and contact your dealer or HIOKI representatives.

- If the unit is definitely damaged.
- If the desired measurement cannot be performed.
- If the unit was stored for extended time in high temperatures and humidity, or in other undesirable conditions.
- If the unit was damaged in transit.
- If "ERROR 20 TO ERROR 24" is displayed.
- If n0 AdJUSt or n0 dA AdJ is displayed when power is turned on.