

DT-209X / DT-209X-S12

Big things come in small packages

Demanded by loyal users of the popular DT-205L laser tachometers, Shimpo responded by creating the DT-209X series of LASER combination hand held tachometers. Based on the DT-205L with its rugged construction and quality components; the DT-209X is equipped with DATA COLLECTION features that adds flexibility in the field for Maintenance, Quality Control and R&D professionals.

Simultaneous storage of data in three different measuring modes (USB, Standard, and Average) both the DT-209X and DT-209X-S12 offer incredible value and ease of use in Contact and Non-contact applications.

Enhanced download features and online controls, showing trending and real time data via USB communication; you can easily access your data by the free software included in each DT-209X package. USB and Analog output included.



DT-209X Software

- 3 Modes of measurement (USB, STANDARD, AVERAGE)
- Selectable units of measure and display refresh interval
- Graph capability in USB mode
- Data can be imported to spreadsheet reports
- Automatic data calculation for Last, Minimum, Maximum and Average readings
- Readings can be set for length and rate measurement
- Smart settings for trigger, max and min limits. (PC will beep indicating out of range data)
- Synchronize time with PC for time stamping
- Multiple data storage in USB mode for different records
- Programmable 1-volt analog output for chart recorders



FEATURES

- 1/4 x 20 mounting hole
- Sophisticated laser beam detection; up to 14'
- Exceptional accuracy
- Length and rate functions
- Multi-mode speed selection
- Length/sec available
- Hardy aluminum construction
- Large 5 digit display
- Expansive memory capacity
- Extended battery life
- Free N.I.S.T. certificate

DIMENSIONS

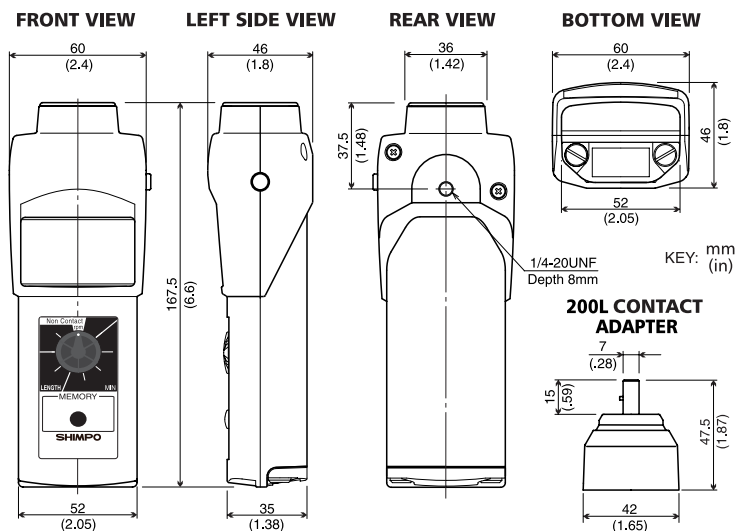

ALSO AVAILABLE



DT-209X shown in Carrying Case.
 12" wheel FPM-12 & FPM-12CBL.

SPECIFICATIONS

MODEL	DT-209X / DT-209X-S12
MEASURING RANGE	6 - 99,999 rpm
MEASURING RANGE CONTACT	0.8 - 25,000 rpm
ACCURACY	±1 rpm: 6 - 8,300 rpm / ±2 rpm: 8,301 - 25,000 rpm / ±0.006 % of reading / ±1 digit (or 7 rpm max.): 25,001 - 99,999 rpm
DISPLAY	5 digit 0.47" (12 mm) high LCD
MEASURING UNIT	rpm: (Non Contact up to 14' away) Contact: ypm, mPM, fpm, ipm and Length; yd, m, ft, in, linear rate and length: using contact adapter included and 6" or 12" circumference wheels.
MEASURING MODE	USB mode; PC online measuring / standard (STD) mode; Standard measuring / Average (AVE) mode; Average data measuring
MEMORY	STD mode; 24 blocks, 10 points/block (Total; 240 data) AVE mode; 30 blocks (Last, Max, Min, Average data in each block) Date and hour of start/finish are stored in each block. (Can download data with USB communication.)
USB COMMUNICATION	USB 1.1
ANALOG OUTPUT	Max. 1 V
DISPLAY UPDATETIME	1 second (typical)
DETECTION	Laser diode
SYSTEM CONTROL	Single-chip C-MOS microprocessor
OVER RANGE INDICATOR	Flashing numerals
VOLTAGE REQUIREMENT	2 AA / 1.5 V Batteries
LOW BATTERY INDICATOR	Flashing "LO BAT" display
AUTOPOWER SHUT-OFF	Yes (except USB mode)
BATTERY LIFE	15 hrs Approx.
OPERATING ENVIRONMENT	Non-corrosive
OPERATING TEMPERATURE RANGE	32° - 113°F (0 - 45°C)
CONSTRUCTION	Die-cast aluminum housing
WEIGHT	DT-209X: 0.9 pound (400g) / DT-209X-S12: 1.0 pound (460g)
DIMENSIONS	6.6" L x 2.4" W x 1.8" H (167.5 mm x 60 mm x 46 mm)
WARRANTY	1 year
STANDARD ACCESSORIES	Reflective tape, 2 cone adapters, funnel adapter, 3 1/2" Extension shaft carrying case, NIST certificate, Master Wheel (6" cir.) and 200L adapter, USB cable, case, NIST certificate, Master Wheel (6" cir.) and 200L adapter, USB cable, Application software (CD-R)

DISTRIBUTED BY

CALRIGHT INSTRUMENTS

The Right Source For Your Test & Measurement Needs

2232 Verus Street Suite D San Diego CA 92154 USA
 Toll Free: 866.363.6634 Tel: 619.429.4545 Fax: 619.374.7012
 Email: sales@calright.com http://www.calright.com