



# HUMICAP® Humidity and Temperature Transmitters HMT120 and HMT130



## Features

- Vaisala HUMICAP® technology with humidity sensor HUMICAP® 180R
- Interchangeable probe (easy field calibration)
- Accurate and reliable
- Resistant to dust and most chemicals
- Enclosure IP65
- 3-point traceable calibration (certificate included)
- Suitable for cleanrooms and demanding HVAC and light industrial applications

Vaisala HUMICAP® Humidity and Temperature Transmitters HMT120 and HMT130 are designed for humidity and temperature monitoring in cleanrooms and are also suitable for demanding HVAC and light industrial applications.

## Options

- Humidity parameter options: relative humidity, dew point/frost point, wet bulb temperature, enthalpy, absolute humidity, mixing ratio, vapor pressure, and saturation vapor pressure
- 2-wire loop-powered or 3-wire voltage output configurations
- Optional LCD display
- USB cable available for a PC connection for maintenance
- Wall-mounted or with a remote probe
- Constant output probe available
- Can be mounted outdoors using a Vaisala installation kit and the Vaisala Radiation Shield DTR504A

## Performance

HMT120/130 incorporates Vaisala HUMICAP® technology that measures relative humidity accurately and reliably. Vaisala HUMICAP® is resistant to dust and most chemicals.

The transmitter enclosure is optimized for use in cleanrooms. The smooth surface of the enclosure makes it easy to clean and the enclosure material is chosen to tolerate purifying agents. Furthermore, the cabling can be done through the back wall of the transmitter.

## Interchangeable Probe

The HMT120/130 transmitters use a fully interchangeable relative humidity probe. The probe can be easily removed and replaced with a new one without having to adjust the transmitter, which allows for

easy and quick recalibration of the transmitter. The probe can be adjusted using one of Vaisala's portable meters as a reference.

Also available is a constant output probe with fixed RH and T output for convenient inspection of the monitoring system and signal transfer line.

## Available Options

The HMT120 and HMT130 transmitters are available as wall mounted or with a remote probe. For high temperature applications or where space is limited, the remote probe is ideal. The optional LCD display shows the measurement results of selected parameters in selected units. The parameters are displayed simultaneously at two separate rows on the display.

# Technical Data

## Measurement Performance

### Relative Humidity

Measurement range	0 ... 100 %RH
Accuracy (including non-linearity, hysteresis, and repeatability) at 0 ... +40 °C (+32 ... +104 °F):	
0 ... 90 %RH	±1.5 %RH
90 ... 100 %RH	±2.5 %RH
Accuracy (including non-linearity, hysteresis, and repeatability) at -40 ... 0 °C, +40 ... +80 °C (-40 ... 32 °F, 104 ... 176 °F):	
0 ... 90 %RH	±3.0 %RH
90 ... 100 %RH	±4.0 %RH
Factory calibration uncertainty at +20 °C (+68 °F):	
0 ... 90 %RH	±1.1 %RH
90 ... 100 %RH	±1.8 %RH
Humidity sensor	Vaisala HUMICAP® 180R
Stability	±2 %RH over 2 years
Stability in typical HVAC applications	±0.5 %RH per year

### Temperature

Measurement range	-40 ... +80 °C (-40 ... 176 °F)
Temperature sensor	Pt1000 RTD Class F0.1 IEC 60751
Accuracy over temperature range:	
At +15 ... +25 °C (59 ... 77 °F)	±0.2 °C (±0.36 °F)
At 0 ... +15 °C and at +25 ... +40 °C (at 32 ... 59 °F and at 77 ... 104 °F)	±0.25 °C (±0.45 °F)
At -40 ... +0 °C and at +40 ... +80 °C (at -40 ... 32 °F and at 104 ... 176 °F)	±0.4 °C (±0.72 °F)

### Other Variables (Optional)

Dew point/frost point, wet bulb temperature, enthalpy, absolute humidity, mixing ratio, vapor pressure, and saturation vapor pressure	
---	--

## Operating Environment

Operating temperature of transmitter body, no display	-40 ... +60 °C (-40 ... 140 °F)
Operating temperature of transmitter body with display	-20 ... +60 °C (-4 ... 140 °F)
Operating temperature, HMP110 probe	-40 ... +80 °C (-40 ... 176 °F)
Storage temperature	-50 ... +70 °C (-58 ... 158 °F)
EMC compliance	EN 61326-1 and EN 55022

## Inputs and Outputs

### HMT120 Two-wire Transmitter (Loop Powered)

Current output signals	4 ... 20 mA
External loop voltage	10 ... 30 VDC ( $R_L = 0 \Omega$ ) 20 ... 30 VDC ( $R_L < 500 \Omega$ )

### HMT130 Three-wire Transmitter

Voltage output signals	0 ... 1 V, 0 ... 5 V, 0 ... 10 V or user defined between 0 ... 10 V
Min output resistance	1 k $\Omega$
Serial output	RS-485, non-isolated
Relay output	1 relay (max. 50 VDC, 200 mA)
Supply voltage	10 ... 35 VDC 15 ... 35 VDC (when output 0 ... 10 V) 24 VAC (±20 %)
Current consumption at 24 VDC	8 mA, if relay closed 15 mA
Max. additional error caused by the analog outputs after calibration at +20 °C (68 °F) ambient temperature	±0.1 % of FS output signal
Temperature dependence of the analog outputs	±0.005 % of FS output signal

## Mechanical Specifications

IP rating	IP65
Weight	270 g
Probe cable lengths	3 m, 5 m, 10 m - up to 50 m
Display (optional)	128 x 64 resolution full graphics B&W display without backlight
<b>Material</b>	
Transmitter housing	PBT plastic
Display window	PC plastic
Probe body	Stainless steel (AISI 316)
Probe grid filter	Chrome coated ABS plastic
<b>Connections</b>	
Inputs and outputs	Screw terminals 0.5 ... 1.5 mm <sup>2</sup>
Probe interface	4-pin M8 female panel connector

## Spare Parts and Accessories

Humidity and temperature probe	HMP110 <sup>1)</sup>
Humidity and temperature replacement probe	HMP110R <sup>1)</sup>
Constant output probe	HMP110REF <sup>1)</sup>
Standard humidity sensor	HUMICAP180R
Catalytic humidity sensor for H <sub>2</sub> O <sub>2</sub>	HUMICAP180V
Probe mounting flange	226061
Probe mounting clamps, 10 pcs	226067
Probe cable 3 m	HMT120Z300
Probe cable 5 m	HMT120Z500
Probe cable 10 m	HMT120Z1000
Probe cable 20 m	HMT120Z2000
Radiation shield	DTR504A
Rain shield with installation kit	215109
Duct installation kit	215619
HM70 connection cable	211339
USB serial interface cable	219685

### HMP110 Sensor Protection

Plastic grid filter	DRW010522SP
Plastic grid with membrane filter	DRW010525SP
Stainless steel sintered filter	HM46670SP
Teflon sintered filter	DRW244938SP

<sup>1)</sup> See separate order form

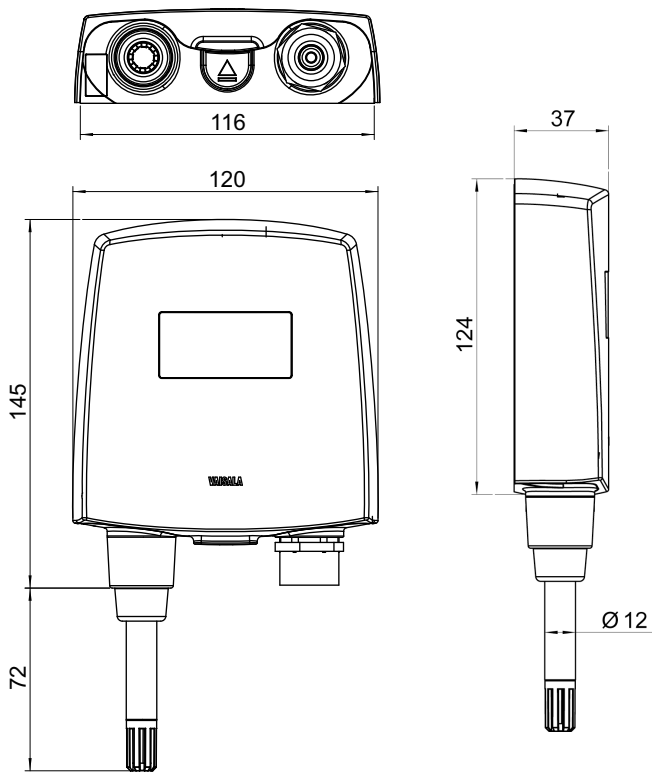

Transmitter dimensions in mm

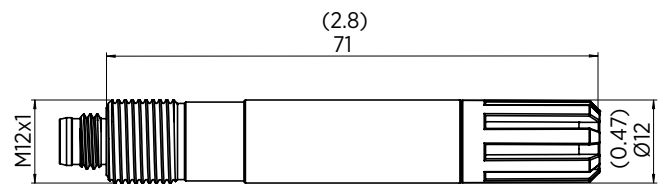

Remote probe dimensions in mm (inches)

