

DIGITAL, ULTRA-HIGH RESISTANCE/ ULTRA-LOW CURRENT METERS

DSM-8104, DSM-8542

DIGITAL SUPER MEGOHMMETERS



DSM-8104 (Single-Channel)



DSM-8542 (Four-Channel)



Options Supporting Measurements such as
Surface and Volume Resistivity



Power Supply Unit

PSU-8541

Fast, Highly Accurate Measurement

$3 \times 10^{16} \Omega$ and 0.1 fA Current Resolution

Measure Capacitance and High Insulation Resistance Quickly and Accurately Test for Current with 0.1 fA Resolution

For practical measurement applications in semiconductor and electronic materials research, a broad range of voltage settings, high 0.1 fA resolution, automatic resistivity calculation, measurement data memory for large values and histogram display of selected measurement results are included as standard features.

Fast measurement for improved productivity

- Capacitive insulating materials are quickly charged by bulk charging terminals to 250 V (at 50 mA) or to 1,000 V (at 10 mA) using a high-capacity, low-noise power source.
- The 100 Ω input impedance remains constant regardless of measurement voltage.
- Measurement sampling time can be set from 2 to 300 ms to support high speed measurements.
- Measurement time is significantly shortened by a patented averaging method (optimization of average time of acceptance of measurement current, Japan Patent No. 3461937).
- The installed charging terminals and handler interface make system support easy.
- Supports data collection on a PC.

- Model DSM-8542 provides high-speed simultaneous measurements on up to four channels when used together with the optional, special-purpose PSU-8541 Power Supply Unit.
- Charging power supply PSU-8541 provides high- and low-voltage channels: 10 V at 600 mA for low-voltage channels, and 250 V at 600 mA to 1,000 V at 120 mA for high-voltage channels, with excellent stability during low-voltage output.
- The PSU-8541 includes charging terminals for up to 20 channels.

Measures ultra-low currents by applied voltage

- Measures current flow with 0.1 fA resolution using any specified applied voltage from 0.1 V to 1,000 V in 0.1 V steps.



Data display with 0.1 fA resolution (10 pA range).

Provides highly reliable measurements

- Contact check function prevents false positive judgments due to poor contact with work.
- Measurement sequence program ensures measurements are taken under the same conditions every time.

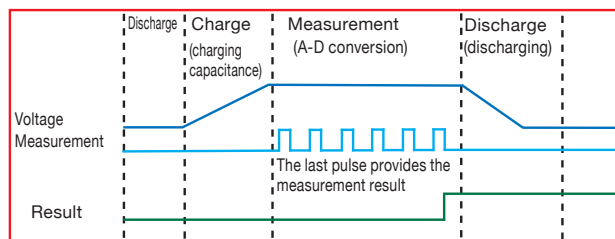

- When measured voltage differs from a preset voltage by more than 3%, a voltage check error notification is issued.

Numerous functions enhance operating efficiency

- Use in combination with the optional SME-8310/8311 Flat Sample Test Fixtures, or with the optional SME-8330 Fluid Resistivity Cell to measure and automatically display surface resistivity or volume resistivity, respectively.



Combined with the optional SME-8310 Flat Sample Test Fixture

- Stores 1,000 measurement data points for searching and display.



Store, search and display data for up to 1,000 measurements.

- Displays percentage and deviation from a reference value.
- Displays histogram of selected results.
- Select from up to ten types of measurement sequences according to the object to be measured.
- Displays the remaining time for each stage of a measurement sequence.
- Measurement settings are displayed together.

DSM-8104



DSM-8542



- Shows the measurement results, conditions and time remaining for the measurement sequence.

Reduced IR Measurement Time for Capacitive Components

The time required to measure the insulation resistance of capacitors and capacitive cables has been a bottleneck to productivity improvement – until now.

The DSM-8104/8542 eliminates this bottleneck with superb measurement efficiency provided by the combination of a high-current power source and a highly sensitive, low-input-impedance current meter.

■ Safety Considerations

- When using a covered measurement fixture (such as the optional SME-8360 Chip Capacitor Test Fixture or SME-8310/8311 Flat Sample Test Fixtures with the optional SME-8350 Shield Enclosure), connected to the instrument with the optional interlock cable, measurement voltage is disabled whenever the lid is opened.
- A red warning lamp indicates whenever measurement voltage of 30 volts or more is present.
- Measurement condition settings are stored even during power outages, although measurement voltage must be applied manually upon recovery.

■ Many Interfaces

- GP-IB, RS-232C and handler interfaces are included as standard. An optional LAN interface is also available.
- * When the optional LAN interface is installed in the main unit, the RS-232C interface cannot be installed at the same time.

Controls and Connectors

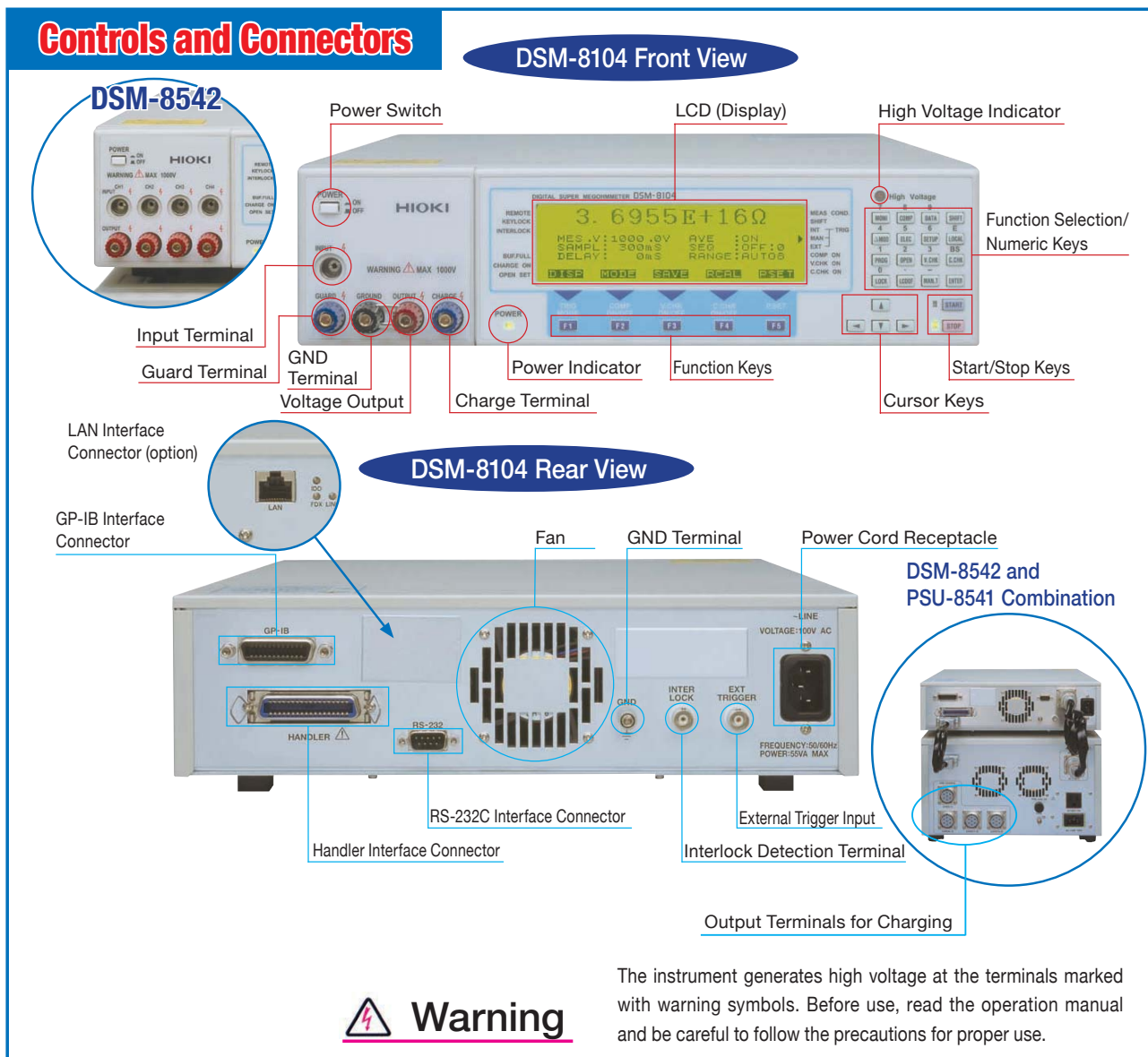

Use the DSM-8104 in Manufacturing, Testing and Research

DSM-8104 (Single-Channel) Application Examples



High-Speed Measurement by Charging with the Charge Terminal

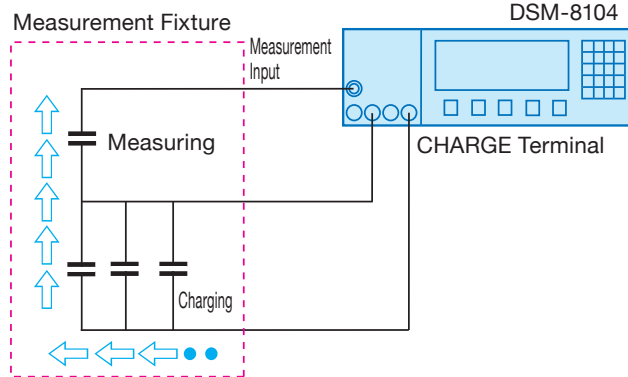

Capacitors are charged before measuring

Research insulation Material using an Electrode Combination

- Evaluate insulating materials using the SME-8310 Flat Sample Test Fixture.



Collect Manual Measurement Data on a Notebook Computer

- A measurement system can be constructed using RS-232C or optional LAN interface. Use your PC to take measurements and process test results.
- The GP-IB and handler interfaces provided in the instrument support measurement systems that include jigs (handlers).

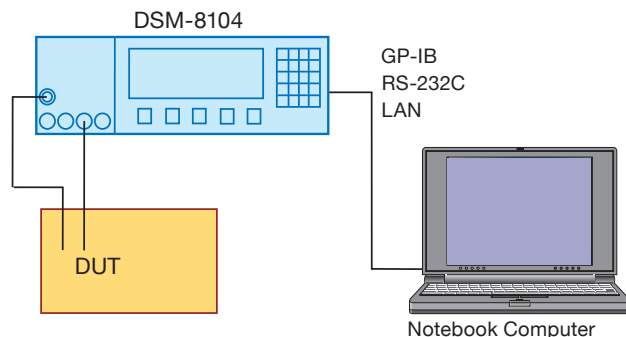

Results of manual measurements are accumulated on the notebook computer.

Test Withstand Voltage of Semiconductor Thin Film (Insulation Breakdown)

- High-sensitivity current measurement is used for withstand voltage testing of semiconductor thin film. (A strong electric field is applied even at low voltage.)
- Insulation breakdown voltage is determined by measuring current flow while gradually increasing the applied voltage.

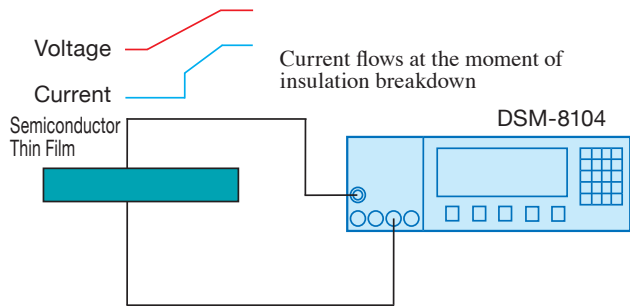

Test Withstand Voltage of Semiconductor Thin Film (Insulation Breakdown)

- Measured values can be categorized and displayed in a bar graph indicating the number of occurrences of each value. The display scale is adjusted automatically so the maximum count always appears at the full display width. Category threshold values can be set as needed.

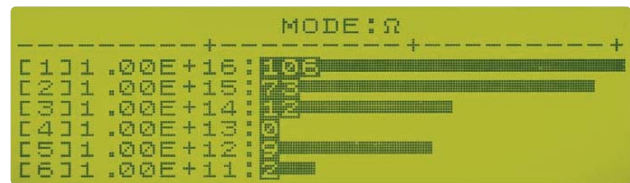

Application Examples

- Measuring insulation resistance of electronic components
Capacitors, connectors, switches, cables and etc.
- Evaluating insulating materials
Coatings, washing fluids, some types of oil and etc.
- Testing anti-static products
Plastics, paint, paper, tile, etc.
- Measuring migration coefficients

CALRIGHT INSTRUMENTS

The Right Source For Your Test & Measurement Needs

8715 Mesa Point Terrace San Diego, CA 92154
Toll Free: 1.866.363.6634 Tel: 1.619.429.4545 Fax: 1.619.374.7012
Email: sales@calright.com <http://www.calright.com>

Use the DSM-8542 to Enhance Electronic Component Automated Production Lines

DSM-8542 (Four-Channel) Application Examples

High-Speed Measurement of Capacitors by Charging with the Charge Terminal

- Twenty channels are used to charge (with current limiting) in parallel using the same voltage as used for measurement. Each terminal is independently current limited.

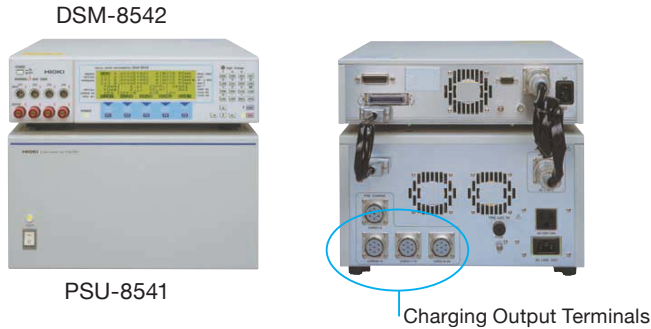

Capacitor Measurement Example

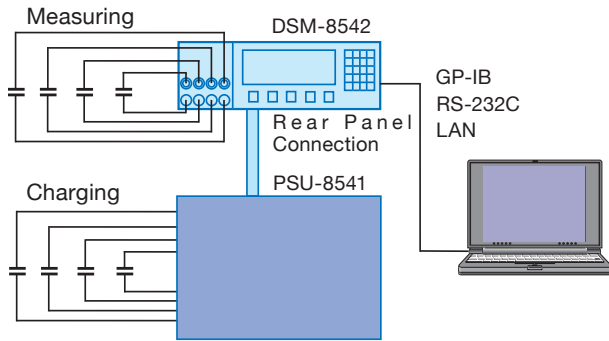

- * Each capacitor is charged for the specified time before connection to a measurement terminal for leakage current measurement.
- * Because there are 20 charging channels and four measurement channels, the time required for charging prior to leakage current measurement can be shorted to one fifth of the time required when using measurement terminals only, increasing measurement throughput by a factor of five.

Measurement Timing

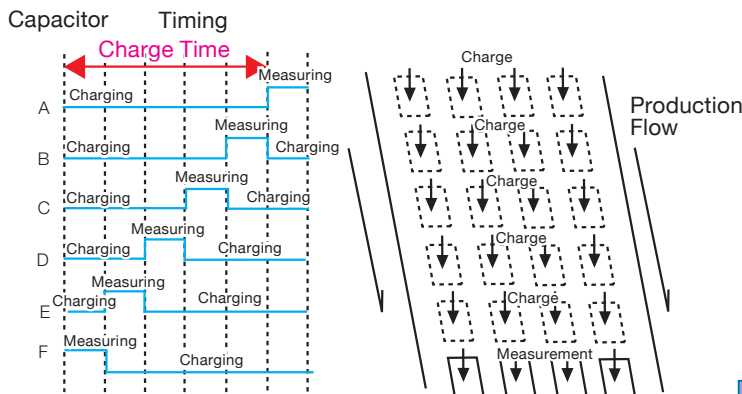

* The description applies to one of the four channels.

Evaluate of Insulating Materials by Four-Point Simultaneous High-Speed Measurement

- For reliability testing of insulation deterioration due to migration of metallic ions in printed circuit boards, measurements are taken simultaneously on four channels, and short intermittent peak current is detected by high-speed measurement (repeated maxima).

Insulating Material Measurement Example

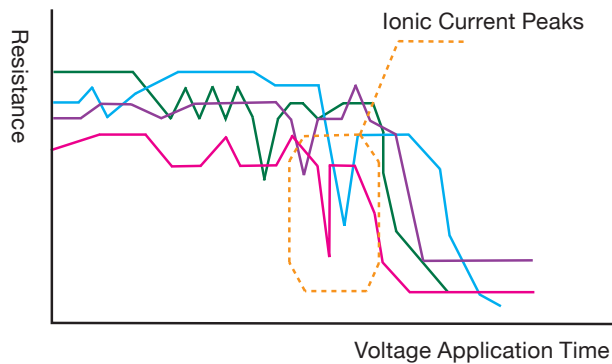
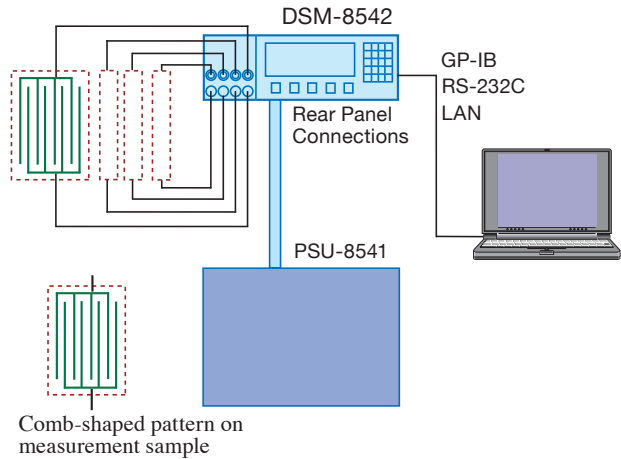

Automatic Testing System Connection Example

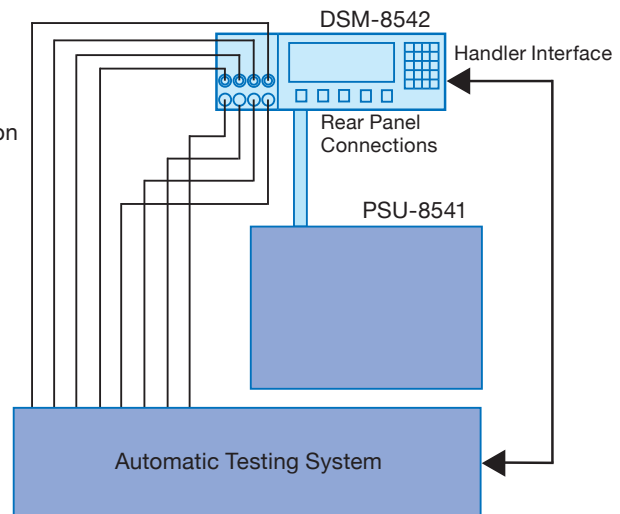

Digital, Ultra-High Resistance/ Ultra-Low Current Meters

DSM-8104 (Single-Channel), DSM-8542 (Four-Channel)

Specifications

Measurement Ranges

DC Measurement Capabilities

Current Measurement			
Measurement Range Name	Maximum Display	Resolution	Accuracy
10 pA	9.9999 pA	0.1 fA	±(3.0% of rdg +1.2% of range)
100 pA	99.999 pA	1.0 fA	±(1.5% of rdg +0.6% of range)
1 nA	999.99 pA	10 fA	±(0.6% of rdg +0.6% of range)
10 nA	9.9999 nA	100 fA	±(0.4% of rdg +0.5% of range)
100 nA	99.999 nA	1 pA	±(0.4% of rdg +0.5% of range)
1 μA	999.99 nA	10 pA	±(0.4% of rdg +0.5% of range)
10 μA	9.9999 μA	100 pA	±(0.4% of rdg +0.5% of range)
100 μA	99.999 μA	1 nA	±(0.4% of rdg +0.5% of range)

* Measurement time is 300 ms, with Average Processing enabled

* Within 23 ±5°C, 85% RH or less, with self-calibration (@1 min. intervals)

* Input impedance is constant at 100Ω

Resistance Measurement Capabilities (1,000 V measurement voltage)

Resistance Measurement		
Range of Measurement	Measurement Range Name	Fundamental Accuracy
$1 \times 10^{14} \sim 3 \times 10^{15}$ (Open-circuit)	10 pA	±4.0% of rdg
$1 \times 10^{13} \sim 1 \times 10^{14}$	100 pA	±4.0% of rdg
$1 \times 10^{12} \sim 1 \times 10^{13}$	1 nA	±2.0% of rdg
$1 \times 10^{11} \sim 1 \times 10^{12}$	10 nA	±0.8% of rdg
$1 \times 10^{10} \sim 1 \times 10^{11}$	100 nA	±0.6% of rdg
$1 \times 10^9 \sim 1 \times 10^{10}$	1 μA	±0.6% of rdg
$1 \times 10^8 \sim 1 \times 10^9$	10 μA	±0.6% of rdg
$1 \times 10^7 \sim 1 \times 10^8$	100 μA	±0.6% of rdg

* Measurement time is 300 ms, with Average Processing enabled

* Within 23 ±5°C, 85% RH or less, with self-calibration (@1 min. intervals)

* Measured values in each measurement range are derived by dividing the measurement voltage by the measured current. Fundamental accuracy applies to the fundamental portion of the measurement accuracy, and depends on the voltage and resistance values.

Measurement Time Setting

Delay	0-9,999 ms
Sampling Time	Time Setting
Power Supply (Line) Frequency Setting	2-300 ms
	1-15 PLC

* PLC denotes the period of one cycle on the commercial power line.

Voltage Generator

Setting Voltage Accuracy and Resolution

Setting Voltage Range	Resolution	Accuracy
0.1-250.0 V	100 mV	±(0.1% of setting +150 mV)
251-1,000 V	1 V	±(0.1% of setting +400 mV)

Current Limiter

Setting Voltage Range	Current Limit Value
0.1-250.0 V	50 mA 10 mA 5 mA
251-1,000 V	10 mA 5 mA

* Current for the voltage sources provided for measuring and charging is as follows:

Current limit value = measurement current + charging power

The charging power supply can be set on or off.

* The current setting error is ±10% of setting

Measurement Check Function

Voltage Monitor	Monitors output voltage and checks that it is within 3% of the specified voltage. When the output voltage is more than 3% from the specified voltage, the V.CHK ON indicator blinks on the display, and a beep sounds.
Contact Check Function	When no contact is detected, the C.CHK ON indicator blinks on the display, and a beep sounds.
Capacitance Range for Contact Detection	Minimum: 0.5 pF, or at least 1/10th of the fixture value
Offset Range for Fixture Capacitance	Maximum: 100 pF (with 0.1 pF resolution)

Measurement Sequence Program Function

Measurement Sequence Program	Ten types of discharge, charge, measure and measurement sequence discharge patterns can be programmed.
	Setting Time: 0 to 999.9 s with 0.1 s resolution

Measurement Data Storage/Display Functions

Measurement Data	Up to 1,000 measurement values can be stored and scrolled sequentially on the display.
Histogram	Measurement values can be categorized and displayed with their sample counts in an on-screen bar graph. Up to ten category thresholds can be set as needed.

Auto-Resume, Calibration and Diagnostic Functions

Auto-Resume Function	Settings and measured values are stored for automatic recovery after a power outage (except for auto voltage application).
Self-Calibration Function	Self-calibration of the A/D converter and current range is performed at specified intervals.
Self-Diagnostic Function	Self-diagnosis of the A/D converter, current range and internal microcontroller memory is performed.

Comparator Measurements

Display Method	When a NO-GO condition is detected, the COMP.ON indicator blinks on the display, and a beep sounds.
Comparison Method	Upper Limit Comparison: Measured Value > Upper Limit (GO decision = HI) Intermediate Comparison: Upper Limit ≥ Measured Value ≥ Lower Limit (GO decision = IN) Lower Limit Comparison: Measured Value < Lower Limit (GO decision = LO)

Deviation/Percentage Measurement

Percentage Measurement method	(Measured Value - Reference Value) / Reference Value × 100
Deviation Measurement	Measured Value - Reference Value

Surface/Volume Resistivity Measurement

Settings	
Surface Resistivity Measurement	Main electrode OD, guard electrode ID
Volume Resistivity Measurement	Main electrode OD, guard electrode ID, DUT thickness For fluid sample electrode: fluid electrode coefficient

External Control Interfaces

I/O Functions	GP-IB Interface Handler Interface RS-232C Interface LAN Interface
---------------	--

Measurement Channel Configuration (DSM-8542)

Number of Measurement Channels	Four Channels
Measurement Input Terminals	Four channels on the front panel (Hioki megohmmeter input connector)
Measurement Input [INPUT]	Four channels on the front panel (binding posts)
Voltage Output [OUTPUT]	Two channels on the rear panel (Round socket)
Voltage Input [A (-), B (-)]	Four channels on the rear panel (Round socket)
Voltage Input [Ch1 (+), Ch2 (+), Ch3 (+), Ch4 (+)]	
Channels, Separation	Channels 1 and 2 share connections Channels 3 and 4 share connections Channels 1 and 2 are separate from channels 3 and 4

General Specifications

Model	DSM-8104 (Single-Channel)	DSM-8542 (Four-Channel)
Display	LCD (8 lines of 30 characters), with backlight (yellow-green LEDs) High voltage warning indicator: Red LED lights at 30 V or more	
Input/Output Terminals	Hioki megohmmeter input connector (INPUT) Binding posts (GND, CHARGE, OUTPUT, GUARD)	Hioki megohmmeter input connector (INPUT × 4) Binding posts (OUTPUT × 4)
Operating Environment	Temperature 0 to 40°C, Humidity 85% RH or less	
Supply Voltage	100 V AC ±10% (standard), 115, 220 or 240 V AC ±10% (factory option), at 50/60 Hz	
Power Consumption	Approx. 55 VA	
External Dimensions	Approx. 332 (W) × 89 (H) × 450 (D) mm	
Weight	Approx. 6.7 kg	Approx. 7.0 kg

Supplied Accessories

Power Cord	1
Instruction Manual	1

* Measurement leads are optional.

* Unless measurement leads are one meter long, the contact check function requires calibration.

Options

Measurement Leads with Test Bar	1 meter long, red	0GE00002
	1 meter long, black	0GE00001
Measurement Leads with Alligator Clips	1 meter long, red	0GA00007
	1 meter long, black	0GA00008
Measurement Leads with one side open	1 meter long, red	0GA00019
	1 meter long, black	0GA00020
Interlock Connection Cable	0.1 meter long	DSM8104F
Rack Mount Adapter		DSM8104E
LAN Interface		DSM8104D

* Please inquire if you need measurement leads other than 1 m long.



Electrodes/ Shielded Enclosures

Options Supporting Measurements such as Surface and Volume Resistivity

ELECTRODE FOR CHIP CAPACITOR SME-8360



The electrodes are for insulation resistance measurement of chip capacitors. The jig can be adjusted anywhere from 0 to 11 mm to measure a wide range of chip capacitors. When the fixture is connected with the interlock connection cable, measurement voltage is disabled when the lid is open.

External Dimensions: Approx. 200 (W) x 52 (H) x 150 (D) mm.
Lead Length: Approx. 85 cm, connects with special HIOKI plug.

SURFACE RESISTANCE MEASUREMENT ELECTRODE SME-8301

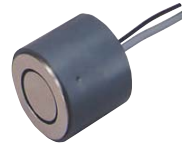

Measures surface resistivity simply by pressing the probe tips on the sample. Primarily intended for use with the SM-8213, to measure surface resistivity of electrostatic-discharge-related samples. Measures up to $10^{10}\Omega$.

External Dimensions: Approx. 60 OD x 50 mm long.
Lead Length: Approx. 1 m, connects with special HIOKI plug.

PLATE SAMPLE ELECTRODE SME-8310



The electrodes are for measuring the characteristic resistivity of flat samples up to 100 mm square and 8 mm thick. The main electrode is 50 mm in diameter, and the guard electrode has 70 mm ID and 80 mm OD. When the fixture is connected with the interlock connection cable, measurement voltage is disabled when the lid is open. A side panel switch easily selects between volume and surface resistivity.

* When used with the DSM-8104, the optional DSM-8104F interlock connection cable is required.

External Dimensions: Approx. 215 (W) x 78 (H) x 165 (D) mm.
Lead Length: Approx. 75 cm, connects with special HIOKI plug.

LIQUID SAMPLE ELECTRODE SME-8330



The electrodes for fluid samples are equipped with a guard. Capacity is 25 mL, capacitance between main and counter electrodes is approximately 45 pF, electrode constant is about 500 cm, inter-electrode spacing is 1 mm, electrode OD is 36 mm and height is about 140 mm. Measures up to $10^{19}\Omega\text{cm}$ (@1,000 V).

Accessory Connection Cable
One each red and black, approx. 60 cm long

CONTINUOUS LIQUID SAMPLE ELECTRODE SME-8335

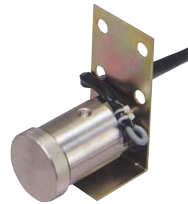

The insulation resistance of fluids such as machine oil or irrigation fluid can be measured in the flowing state through 1/4-inch NPT joints. The cell can be mounted through U-bolts using the supplied metal bracket. Container volume is about 30 mL, and electrode constant is about 75 cm.

External Dimensions: Approx. 58 OD x 80 mm height.
Lead Length: Approx. 5 m, with special HIOKI plug.

ELECTRODE FOR FLAT SAMPLE SME-8311



The electrodes are for measuring characteristic resistivity of flat samples up to 40 x 100 mm and 8 mm thick. The main electrode is 19.6 mm in diameter, and the guard electrode has 24.1 mm ID and 28.8 mm OD. Appearance and usage methods are the same as for the SME-8310.

* When used with the DSM-8104, the optional DSM-8104F interlock connection cable is required.

External Dimensions: Approx. 215 (W) x 78 (H) x 165 (D) mm
Lead Length: Approx. 75 cm, connects with special HIOKI plug.

SHIELDING BOX SME-8350



This enclosure provides electromagnetic shielding when measuring samples with high insulation resistance or reactance. When used with the SME-8320 Weight Electrodes, it provides the counter or guard electrode. When measuring electronic components such as capacitors and transformers, it shields against external noise and leakage current to provide stable measurements. * When used with the DSM-8104, the optional DSM-8104F interlock connection cable is required.

External Dimensions: Approx. 250 (W) x 100 (H) x 200 (D) mm.
Lead Length: Approx. 80 cm, with special HIOKI plug.

WEIGHT ELECTRODE SME-8320



These electrodes for flat samples are used in combination with the SME-8350 Shielded Enclosure. Easily measures surface and volume resistivity of even coarse surfaces such as carpet. The main electrode is 50 mm in diameter, and the guard electrode has 70 mm ID and 80 mm OD. The jig for concentric electrodes is included.

Accessories Two banana plugs
Illustrated with the SM-8350 shielded enclosure.

ELECTRODE FOR SURFACE RESISTANCE SME-8302



This two-electrode probe is suitable for surface resistivity measurement of curved surfaces such as molded resin and rubber products, and for small samples. Measures surface resistivity simply by pressing the probe tips on the sample. Electrode spacing is 10 mm, and measures up to $10^{10}\Omega$. (4 mm inter-electrode spacing)

STANDARD RESISTOR SR-2



This resistance box is designed for calibrating Hioki's series of ultra insulation testers. The construction ensures secure connection between the box and the tester. Maximum operating voltage is 1,000 V DC, and it provides 24 resistance values between 10 M Ω and 10,000 M Ω .

External Dimensions: Approx. 270 (W) x 90 (H) x 195 (D) mm

External Dimensions: Approx. 40 mm OD x 115 mm long.
Lead Length: Approx. 1 m, connects with special HIOKI plug.

PSU-8541

Low-Noise, High-Capacity Power Supply for Stable Charging Output

Specifications

Configuration

Constituents	No. of Circuits	Configuration	Remarks [Continuous ratings in parentheses ()]
Voltage Generator A (HIGH)	1		150.0 W (50 W) / 250 V
Voltage Generator B (LO)	1		120.0 W (50 W) / 1,000 V 6.0 W / 10 V
Current Control Circuit (Measurement System) (Charge System)	4 20	Two circuits shared by two pairs Five circuits shared by four groups	

* High and low voltage amplifiers and current limiter connections are by internal terminal block (when external control not used).

* Either one or both of systems A and B may be earthed systems.

Voltage Generator – Setting Voltage Accuracy and Resolution

Setting Voltage Range	Current Capacity (continuous rating)	Setting Resolution	Accuracy
Voltage Generator A (HIGH) 0.1 to 250.0 V	Max. 600 mA (200 mA)	100 mV	±(0.1% of setting +150 mV)
251 to 1,000 V	Max. 120 mA (50 mA)	1 V	±(0.1% of setting +400 mV)
Voltage Generator B (LO) 0.1 to 10.0 V	Max. 600 mA	100 mV	±(0.1% of setting +150 mV)

* Values in parentheses () are continuous ratings of current capacity

Current Limiter Configuration

Current Limit Value, Voltage Range	Voltage Range, Current Capacity, Current Limit Setting		Current Value			Voltage Source, Current Capacity
	Measurement System	Charge System	Measurement System	Charge System	All Loads	
251–1,000 V	5 mA	5 mA	5 mA × 4	5 mA × 5 × 4	120 mA	120 mA (50 mA)
0.1–250.0 V	5 mA	5 mA	5 mA × 4	5 mA × 5 × 4	120 mA	600 mA (200 mA)
	5 mA	10 mA	5 mA × 4	10 mA × 5 × 4	220 mA	
	5 mA	25 mA	5 mA × 4	25 mA × 5 × 4	520 mA	
	5 mA	50 mA	5 mA × 4	50 mA × 2 × 4	420 mA	
	10 mA	5 mA	10 mA × 4	5 mA × 5 × 4	140 mA	
	10 mA	10 mA	10 mA × 4	10 mA × 5 × 4	240 mA	
	10 mA	25 mA	10 mA × 4	25 mA × 5 × 4	540 mA	
	10 mA	50 mA	10 mA × 4	50 mA × 2 × 4	440 mA	
	25 mA	5 mA	25 mA × 4	5 mA × 5 × 4	200 mA	
	25 mA	10 mA	25 mA × 4	10 mA × 5 × 4	300 mA	
	25 mA	25 mA	25 mA × 4	25 mA × 5 × 4	600 mA	
	25 mA	50 mA	25 mA × 4	50 mA × 2 × 4	500 mA	
	50 mA	5 mA	50 mA × 4	5 mA × 5 × 4	300 mA	
	50 mA	10 mA	50 mA × 4	10 mA × 5 × 4	400 mA	
	50 mA	25 mA	50 mA × 4	25 mA × 5 × 4	600 mA	
	50 mA	50 mA	50 mA × 4	50 mA × 2 × 4	600 mA	

* When overall load current exceeds the current capacity of the voltage source, its voltage drops.

* Values in parentheses () are continuous ratings of current capacity.

* When the continuous load rating is exceeded, voltage of the voltage source drops.



Control

Controller	Controlled by the DSM-8542
Controlled Object	Voltage Setting, Current Limit for Measurement, Current Value Setting (common for all channels)
	Current Limit for Charging, Current Value Setting (common for all channels)
	Voltage Output On/Off
	Voltage Generator Filter On/Off
Control Method	Special-Purpose Cable and Interface

* Values in parentheses () are continuous ratings of current capacity

General Specifications

Operating Environment	Temperature 5 to 35°C, Humidity 85% RH or less
Supply Voltage	100 V AC ±10% at 50/60 Hz
Power Consumption	Max. Approx. 350 VA
External Dimensions	Approx. 332 (W) × 178 (H) × 450 (D) mm
Weight	Approx. 28 kg

Supplied Accessories

Power Cord	1
DSM-8542 Connection Cable A	1
DSM-8542 Connection Cable B	1
Instruction Manual	1

Options

Rack Mount Adapter	LMA-PSU
--------------------	---------