

## temperature



### Wide temperature range

DTI050: -200 to 2500°C (-328 to 4532°F)  
 STS-050 probe: -50 to 400°C (-58 to 752°F)  
 STS-100 probe: -150 to 650°C (-238 to 1202°F)  
 STS-102 probe: -45 to 155°C (-49 to 311°F)

### Improve your accuracy

DTI050: accuracy to  $\pm 0.005^\circ\text{C}$  ( $\pm 0.009^\circ\text{F}$ )  
 DTI050 + STS probe:  
 accuracy to  $\pm 0.04^\circ\text{C}$  ( $\pm 0.072^\circ\text{F}$ )

### Intelligent sensor

Critical information stored in a memory chip in the intelligent sensor gives easy access to relevant data and avoid mistakes

### Minimize paperwork

RS232 communication, special calibration and data storage software are included

### Fast response time

Ensures correct monitoring of the temperature stability

### Specified low drift

Maintains a minimum uncertainty budget throughout the period between re-calibration intervals

### Wide selection of probes

Straight probes, 90° angled probes or cable probes, offering flexibility in test methods depending on the sensor-under-test

### True field calibrator

Low temperature coefficient - high accuracy in the lab and in the field

ISO 9001 Manufacturer



*The Right Source For Your Test & Measurement Needs*

2232 Verus Street Suite D San Diego CA 92154 USA  
 Toll Free: 866.363.6634 Tel: 619.429.4545 Fax: 619.374.7012  
 Email: sales@calright.com <http://www.calright.com>

## JOFRA™ DTI050

### Digital Temperature Indicator

Handheld reference indicator offering traceable temperature measurement

AMETEK Calibration Instruments has broadened the DTI program by introducing the small sized and easy-to-use reference indicator JOFRA DTI050.

Combined with an accurate JOFRA STS temperature reference sensor, the DTI050 temperature reference indicator is the perfect reference thermometer.



### PRODUCT DESCRIPTION

The JOFRA DTI050 with an JOFRA STS temperature reference sensor is a fully traceable thermometer recommended as the reference instrument to verify true temperature in any type of temperature calibrator, liquid bath, or dry-block calibrator.

Use the JOFRA DTI050 and the STS probes as your working temperature reference in any calibration application or use the set-up directly for critical measurements in the process.

The superior specifications, combined with a long history of reliability and low drift, make the JOFRA DTI050 and the JOFRA STS probes the perfect choice.

The graphical display makes it is easy to recognize the status of the instrument and take readings.

The DTI050 also handles signals from 4-wire RTD's, TC's and thermistors.

**AMETEK®**  
 CALIBRATION INSTRUMENTS

**Graphical display**

Large digits display the temperature, info lines show current status and mode, and the small digits show the details of the sensor.

**Indicator for low battery**

Running low on battery an icon in the display clearly shows this

**ON / OFF**

Auto shut-off to extend battery life (user-programmable).

**Resolution**

1 °C - 0.001 °C. Maximum resolution depends on the selected sensor type.

**Hold**

Makes it possible to "freeze" the results when doing measurement. The results are saved in the EEPROM, when it is switched off.

**External power supply**

It is possible to connect the DTI050 to external 9V supply.

**Intelligent probe reading**

Capable of reading calibration data and other information from the memory of the sensor (standard when using the STS-050 sensors and optional on the STS-100 sensors).

**Input**

1 input channel with 6-pin REDEL connector.

**Type**

Select type of sensor. When using an STS reference sensor with intelligence, the indicator automatically finds the sensor and the data.

**Serial interface**

RS232 serial interface to communicate with JOFRA - CAL calibration software. Also used if adjustment of the unit is necessary.

**MAX / MIN**

Reads the highest and lowest value from last reset. Monitor a safety alarm or look for temperature spikes in the process. Min and max are saved in the EEPROM, when it is switched off.

**Useful softcase**

The DTI050 indicator is supplied in a handy softcase as standard. The softcase that protects the instrument is a useful part of the instrument. The softcase is designed for easy vertical operation so when opening the case, there is easy access to all accessories in the pocket. A flap on top of the softcase provides access to the temperature sensor.

The softcase includes a shoulder strap for convenient transportation of the instrument when climbing ladders, etc. At the back of the case, a handy strap that fits the hand also makes it possible to hang the instrument on a pipe, ladder or the like while performing the calibration, test, or service task.



**JOFRA STS-050 reference sensors**

JOFRA STS Superior Temperature reference sensors are based on more than 50 years of industrial temperature sensor manufacturing experience. The main requirement of a reference probe is stability: The less the probe drifts, the lower the measurement uncertainty. All JOFRA Superior Temperature Standard probes are economical and offer fast response times, low immersion depths, compact physical sizes, and specified low drift rates: even at high temperatures. These are all important considerations when selecting a reference sensor.

Especially for the DTI050 reference indicator, AMETEK has developed a specific series of reference sensors, - the JOFRA STS-050 Superior Temperature reference sensor, which are built to last.

**JOFRA STS reference sensors and system accuracy**

To get an ideal reference system, JOFRA offers a range of reference sensors for the JOFRA DTI050, as it is also possible to use the JOFRA DTI050 with JOFRA STS-100 and JOFRA STS-102 reference sensors.

System accuracy:

STS-050 probe with handle (see more at page 11):

-50 to 250°C (-58 to 482°F):	±0.040°C (±0.072°F) 1) 2)
	±0.060°C (±0.108°F) 1) 3)
-50 to 400°C (-58 to 752°F):	±0.065°C (±0.117°F) 1) 2)
	±0.090°C (±0.162°F) 1) 3)

STS-100 probe (see more at page 8):

-50 to 250°C (-58 to 482°F):	±0.040°C (±0.072°F) 1) 2)
	±0.055°C (±0.099°F) 1) 3)
-50 to 320°C (-58 to 608°F):	±0.050°C (±0.090°F) 1) 2)
	±0.060°C (±0.108°F) 1) 3)
-50 to 400°C (-58 to 752°F):	±0.065°C (±0.117°F) 1) 2)
	±0.080°C (±0.144°F) 1) 3)
-50 to 650°C (-58 to 1202°F):	±0.090°C (±0.162°F) 1) 2)
	±0.100°C (±0.180°F) 1) 3)

STS-102 cable sensor (see more at page 9):

-45 to 155°C (-49 to 311°F):	±0.040°C (±0.072°F) 1) 2)
	±0.070°C (±0.126°F) 1) 3)

All sensors are supplied with an accredited or traceable certificate from a National Accredited Laboratory, stating the sensor coefficients.

Note 1: Specified at 95% confidence interval k=2, over full range, including calibration uncertainty, excluding 1 LSD (Least Significant Digit).

Note 2: Excl. sensor drift (please see long term stability at page 5)

Note 3: Incl. sensor drift (please see long term stability at page 5) after 100 hours at max. temperature.



**CON050 configuration software for special sensor coefficients**

The JOFRA DTI050 uses intelligent detection technology for sensors. This means that it is able to automatically read calibration data and sensor type from a memory chip placed in the sensor. This chip is standard in the STS-050 series and is optional on the STS-100 series.

The intelligent sensor reading makes it possible to change the sensors used without re-programming your DTI050. When an intelligent sensor is connected, all information about the probe, such as serial number, calibration data and coefficients are read by DTI050. All information can be shown on the display in the config menu for verification. Recalling existing data eliminates errors as a result of programming sensor data.

For updating the information stored in the sensor, DTI050 is supplied with the CON050 configuration software that allows you to edit all information stored in the probe. This includes CVD or ITS90 coefficients for RTD's, Steinhart Hart coefficients for Thermistors and a second order deviation function for TC-sensors.



**Simplified temperature calibration documentation**

The DTI050 features an RS232 serial data communication interface. This allows the instrument to be serially connected to a personal computer for data storage and reporting.

The JOFRACAL calibration software supports automatic calibration of all JOFRA temperature dry-block calibrators via RS232 serial data interface including the JOFRA DTI050 digital thermometer, the JOFRA DTI-1000 digital thermometer and the JOFRA ASM Multi-scanner.

For semi-automatic calibrations, the software also supports liquid baths, ice points, or other dry-block heating and cooling sources. Using the software's "SCENARIO" function allows for combining instruments in virtually any configuration, including using the DTI050 either as a temperature reference or as an input module for the sensor-under-test.

JOFRACTAL calibration software is menu-driven and easy to use, with a complete software controlled calibration procedure, which saves time. This software allows the user to customize his or her calibration routines. The software is easy-to-use so you do not have to be a programmer to configure your own calibration procedures. The software features prompts, menus, and help functions that guide you through the configuration process. Once all calibrations are completed, the JOFRACAL calibration software can be used for post-processing and printing of certificates. The calibration data collected may be stored in the personal computer for later recall or analysis.

**INPUT SPECIFICATIONS FOR DTI050**

4-wire RTD Type	Temperature range				12 months accuracy	
	°C		°F		°C	°F
	From	To	From	To		
PT385, 10 ohm	-200	-80	-328	-112	0.057	0.102
	-80	0	-112	32	0.063	0.113
	0	100	32	212	0.067	0.121
	100	300	212	572	0.081	0.146
	300	400	572	752	0.088	0.158
	400	630	752	1166	0.103	0.185
PT385, 50 ohm	-200	-80	-328	-112	0.017	0.030
	-80	0	-112	32	0.027	0.048
	0	100	32	212	0.025	0.045
	100	300	212	572	0.036	0.064
	300	400	572	752	0.041	0.074
	400	630	752	1166	0.053	0.095
PT385, 100 ohm	-200	-80	-328	-112	0.012	0.021
	-80	100	-112	212	0.020	0.036
	100	300	212	572	0.030	0.054
	300	400	572	752	0.035	0.063
	400	630	752	1166	0.047	0.084
	630	800	1166	1472	0.057	0.102
PT3926, 100 ohm	-200	-80	-328	-112	0.011	0.021
	-80	0	-112	32	0.015	0.027
	0	100	32	212	0.019	0.035
	100	300	212	572	0.029	0.051
	300	400	572	752	0.034	0.062
	400	630	752	1166	0.046	0.082
PT3916, 100 ohm	-200	-190	-328	-310	0.006	0.012
	-190	-80	-310	-112	0.012	0.021
	-80	0	-112	32	0.015	0.027
	0	100	32	212	0.019	0.035
	100	260	212	500	0.028	0.050
	260	300	500	572	0.029	0.051
PT3916, 50 ohm	-200	-190	-328	-310	0.011	0.020
	-190	-80	-310	-112	0.017	0.030
	-80	0	-112	32	0.020	0.036
	0	100	32	212	0.025	0.044
	100	260	212	500	0.033	0.060
	260	300	500	572	0.034	0.061
PT385, 200 ohm	-200	-80	-328	-112	0.032	0.057
	-80	0	-112	32	0.036	0.065
	0	100	32	212	0.041	0.074
	100	260	212	500	0.045	0.081
	260	300	500	572	0.053	0.095
	300	400	572	752	0.057	0.102
PT385, 400 ohm	-200	-80	-328	-112	0.019	0.035
	-80	0	-112	32	0.030	0.054
	0	100	32	212	0.034	0.061
	100	300	212	572	0.039	0.069
	300	400	572	752	0.044	0.079
	400	630	752	1166	0.056	0.101

4-wire RTD Type	Temperature range				12 months accuracy		
	°C		°F		°C	°F	
	From	To	From	To			
PT385, 500 ohm	-200	-80	-328	-112	0.017	0.030	
	-80	0	-112	32	0.020	0.036	
	0	100	32	212	0.025	0.045	
	100	260	212	500	0.033	0.060	
	260	300	500	572	0.035	0.062	
	300	400	572	752	0.041	0.074	
PT385, 1000 ohm	-200	-80	-328	-112	0.012	0.021	
	-80	0	-112	32	0.015	0.028	
	0	100	32	212	0.020	0.037	
	100	260	212	500	0.028	0.050	
	260	300	500	572	0.030	0.054	
	300	400	572	752	0.034	0.061	
NI120 672	-80	260	-112	500	0.012	0.022	
	-60	179	-76	354	0.013	0.023	
	-200	-190	-328	-310	0.007	0.013	
	-190	-80	-310	-112	0.012	0.021	
	-80	0	-112	32	0.015	0.028	
	0	100	32	212	0.020	0.037	
JIS	100	260	212	500	0.028	0.050	
	260	300	500	572	0.029	0.052	
	300	400	572	752	0.034	0.061	
	400	630	752	1166	0.047	0.084	
	CU10 427	-100	260	-148	500	0.069	0.124
	Cu50 428	-180	199	-292	390	0.027	0.048
Cu100 428	-180	199	-292	390	0.022	0.039	
Cu 50 426	-50	150	-58	302	0.025	0.044	
Cu100 426	-50	150	-58	302	0.020	0.036	
Cu53 426	-50	179	-58	354	0.025	0.045	

Ohm	Range		Accuracy ±
	min	max	12 months
Ohm read (low)	0.000	400.000	0.004% rdg +0.002 ohm
Ohm read (high)	400.00	4000.00	0.004% rdg +0.02 ohm
Ohm read (thermistor) kohm	0	200	±0.02%rdg ±2.0 Ohms
Ohm read (thermistor) kohm	200	500	±0.03%rdg

Thermocouple mV	Range		Accuracy ±
	min	max	12 months
TC mV read	-10.000 mV	75.000 mV	0.005% rdg +5µV

Thermocouple Cold junction	Range		Accuracy ±
	min	max	12 months
CJ compensation	18°C / 64°F	28°C / 83°F	0.2°C / 0.36°F
CJC outside above			0.05°C/°C 0.05°F/°F

**FURTHER SPECIFICATIONS**

TC Type	Temperature range				12 months accuracy	
	°C		°F		°C	°F
	From	To	From	To		
B	600	800	1112	1472	0.66	1.18
	800	1000	1472	1832	0.64	1.16
	1000	1550	1832	2822	0.65	1.18
	1550	1820	2822	3308	0.67	1.21
C	0	150	32	302	0.25	0.45
	150	650	302	1202	0.24	0.43
	650	1000	1202	1832	0.26	0.47
	1000	1800	1832	3272	0.47	0.85
	1800	2316	3272	4201	0.81	1.46
E	-250	-100	-418	-148	0.47	0.84
	-100	-25	-148	-13	0.10	0.19
	-25	350	-13	662	0.11	0.20
	350	650	662	1202	0.09	0.17
	650	1000	1202	1832	0.12	0.21
J	-210	-100	-346	-148	0.24	0.43
	-100	-30	-148	-22	0.12	0.21
	-30	150	-22	302	0.11	0.20
	150	760	302	1400	0.13	0.23
K	760	1200	1400	2192	0.15	0.27
	-200	-100	-328	-148	0.31	0.56
	-100	-25	-148	-13	0.16	0.28
	-25	120	-13	248	0.14	0.25
L	120	1000	248	1832	0.18	0.33
	1000	1372	1832	2502	0.23	0.41
	-200	-100	-328	-148	0.34	0.61
	-100	800	-148	1472	0.24	0.43
N	800	900	1472	1652	0.14	0.25
	-200	-100	-328	-148	0.48	0.87
	-100	-25	-148	-13	0.23	0.42
	-25	120	-13	248	0.20	0.37
R	120	410	248	770	0.19	0.34
	410	1300	770	2372	0.20	0.37
	0	250	32	482	0.96	1.73
	250	400	482	752	0.55	1.00
S	400	1000	752	1832	0.53	0.96
	1000	1767	1832	3213	0.49	0.89
	0	250	32	482	0.94	1.70
	250	1000	482	1832	0.62	1.12
T	1000	1400	1832	2552	0.50	0.89
	1400	1767	2552	3213	0.57	1.03
	-250	-150	-418	-238	0.74	1.33
	-150	0	-238	32	0.21	0.38
U	0	120	32	248	0.14	0.24
	120	400	248	752	0.13	0.23
	-200	0	-328	32	0.52	0.94
	0	600	32	1112	0.25	0.45
BP	200	600	392	1112	0.3	0.54
	600	800	1112	1472	0.38	0.68
	800	1600	1472	2912	0.44	0.79
	1600	2000	2912	3632	0.56	1.01
	2000	2500	3632	4532	0.78	1.40
XK	-200	-100	-328	-148	0.21	0.38
	-100	300	-148	572	0.13	0.23
	300	800	572	1472	0.19	0.34

**Environmental conditions**

Operating temperature ..... -10 to 50°C / 14 to 122°F  
 Storage temperature ..... -20 to 60°C / -4 to 140°F  
 Atmospheric humidity ..... 0 to 90%  
 All specifications specified at ambient temperature ..... 23°C ±5°C / 73°F ±9°F  
 Outside ambient 23°C ±5°C ..... ±0.001% rdg/°C  
 Outside ambient 73°F ±9°F ..... ±0.0028% rdg/°F  
 CJ compensation 18 to 28°C / 64 to 83°F ..... 0.2°C / 0.36°F  
 CJC outside above ..... 0.05°C/°C / 0.05°F/°F

**Power supply**

Mains ..... 9 VDC / 200 mA  
 Battery ..... 1 x 9 VDC Alkaline  
 Battery life ..... Minimum 10 hours  
 Low battery indicator ..... at 6 VDC  
 Auto off ..... 1-30 minutes

**Display**

LCD ..... Graphical display  
 Display resolution ..... 5 digits  
 Display update ..... twice per second

**RS232 communication interface**

Connector ..... 3-pin JACK  
 Communication rate ..... 9600 baud, ASCII

**Instrument dimensions**

Indicator L x W x H ..... 188 x 84 x 52 mm / 7.4 x 3.3 x 2.1 in  
 Indicator weight (including battery) ..... 400 g / 14.1 oz

**Shipping dimensions**

Indicator L x W x H ..... 250 x 160 x 100 mm / 9.8 x 6.3 x 3.9 in  
 Indicator weight (including battery) ..... 1.1 kg / 2.4 lb



## ORDERING INFORMATION DTI050

Order No.	Description
DTI050	Temperature Indicator DTI050 Temperature Indicator
	Calibration certificate NIST traceable certificate (standard)
G	NIST traceable certificate (standard)
H	Accredited certificate
	Options
C	Carrying Case (max. 350 mm. straight probe)
X	No option used
DTI050GX	Sample order number JOFRA DTI050 temperature indicator with standard NIST traceable calibration certificate.

## STANDARD DELIVERY

- DTI050 indicator
- NIST traceable calibration certificate in ohm and mV
- Softcase and shoulder strap
- User manual
- 9V battery
- RS232 cable
- JOFRACAL calibration software
- CON050 configuration software

## Specifications JOFRACAL and CON050 software

## Minimum hardware requirements:

- INTEL™ 486 processor  
(PENTIUM™ 800 MHz recommended)
- 32 MB RAM (64 MB recommended)
- 80 MB free disk space on hard disk prior to installation
- Standard VGA (800 x 600, 16 colors) compatible screen  
(1024 x 786, 256 colors recommended)
- CD-ROM drive for installation of the program
- 1 free RS232 serial port

## Carrying case (Optional) - 125812

A complete ready-to-use system may be delivered in a practical aluminum carrying case, which can hold the DTI050 and all standard accessories as well as a STS reference sensor.

(Max. 350 mm. STS-050 reference sensor)



## ACCESSORIES

## FP Industrial temperature sensors

Temperature is one of the most measured parameters within industry and science. A correct measurement is of great importance to the quality of the product, as well as to the security and the energy consumption. Therefore, it is very important to choose the right sensor for the actual application.

Based on long-standing experience with development, production and sales of FP industrial temperature sensors, AMETEK has worked out a unique selection system facilitating the work when ordering industrial temperature sensors - and at the same time ensuring the optimal choice. The system can handle several million types without sacrificing the clarity. Only 51 "spec sheets" and a "Sensor Guide" now enable the user to design and adapt the sensors, which is the optimal choice for his application.

Especially for the DTI050 temperature indicator, AMETEK can offer the following standard FP industrial temperature sensors without certificate and intelligent connector:

- 125709 Universal sensor, with Pt100 and handle  
150 mm, Ø3 mm, -50 to 250°C
- 125710 Air-/room sensor, with Pt100 and handle  
100 mm, Ø6 mm, -50 to 250°C
- 125711 Needle sensor, with Pt100 and cross grip in stainless steel  
100 mm, Ø3 mm, -50 to 250°C
- 125712 Needle sensor, with Pt100 and handle  
100 mm, Ø3 mm, -50 to 250°C
- 125713 Universal sensor, with TC-K and handle  
150 mm, Ø1.5 mm, max. 850°C
- 125714 Universal sensor, with TC-K and handle  
150 mm, Ø3 mm, max. 1000°C
- 125715 Air-/room sensor, with TC-K and handle  
100 mm, Ø6 mm, max. 250°C
- 125716 Needle sensor, with TC-K and cross grip in stainless steel,  
100 mm, Ø3 mm, max. 400°C
- 125717 Needle sensor, with TC-K and handle  
100 mm, Ø3 mm, max. 400°C
- 125708 Reference sensor, with TC-N and intelligent connector  
500 mm, Ø4,5 mm, max. 1205°C
- 125814 Reference sensor, with TC-N, intelligent connector and  
accredited certificate, 500 mm, Ø4,5 mm, max. 1205°C

If any special industrial temperature sensors are required, AMETEK is pleased to help with a solution.

## DTI050 power supply accessories

- 124717 1 x 9V rechargeable battery
- 124718 Charger for 124717 battery, 115/230 VAC
- 124720 Mains adapter 9VDC/200mA - 230VAC/115VAC

## DTI050 connection accessories

- 125702 Connector for RTD sensors without intelligence
- 125703 Connector for RTD sensors with intelligence
- 125759 Connector for TC sensors without intelligence
- 125704 Connector for TC sensors with intelligence
- 125522 2 m. adaptor cable to LEMO connector with intelligence for use with STS-100 and STS-102 sensors
- 125521 2 m. adaptor cable to Banana connectors with intelligence
- 125523 2 m. adaptor cable to mini TC-connector with intelligence

# JOFRA™ STS Series

## Quality defined

It is not easy to make a good quality reference sensor. The main requirement of a reference probe is stability. This means minimal drift as a function of operating time at the actual temperature. The less the probe drifts, the lower the measurement uncertainty.

## Small diameter - fast response

The STS-050 A/B and STS-100 A/B series has a relatively small diameter. This leaves optimum space for sensors-under-test in the dry-block and ensures a fast response time. A fast reacting sensor will optimize the measurement information.

In addition to straight probes in 4 mm and 1/4 in, AMETEK also offers a 90° angled version specifically developed for use with dry-block temperature calibrators. This probe allows the user to have both the sensor-under-test and the reference probe in the thermowell at the same time: even if the sensors have a connection or a transmitter head.

## Reduced hysteresis and drift

The main reason for drift within a sensor assembly is impurities within the element, especially at temperatures above 350°C (660°F). All internal parts must be cleaned thoroughly.

The assembly of the components is performed in a clean room. These precautions ensure minimum contamination of the element during use and provide the user with the best possible performance.

## Ageing/annealing

Once the probes are assembled, they are subjected to a long approval process. This includes mechanical stress reduction of the entire assembly as well as ageing the sensor element itself. The purpose of ageing the sensor is to remove the initial drift.

The procedure involves heating the sensor up to maximum and holding it for 1 hour before cooling down. This process is repeated over a period of several days. The resistance is then measured at 0°C (32°F) and recorded. The sensor is again heated up to maximum, and this time the temperature is held constant for 100 hours.

Finally, the output from the sensor is again measured at 0°C (32°F) and recorded. The difference between the first and the second measurement is recorded. The difference between these two measurements is our verification of the stability qualities of the sensor. To be accepted for final calibration and certification, the probe must meet our minimum tolerance.

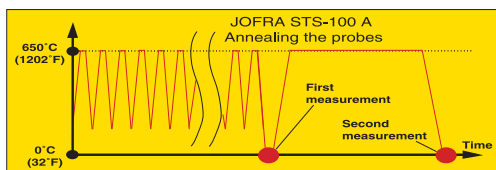

## Reduced isolation-resistance-error

Electrical isolation resistance (parasite-resistance-error), when measured at the highest operating temperature, should be as high as possible. A low isolation resistance would cause the output signal to be incorrect in relation to the temperature.

JOFRA STS-050 A/B and STS-100 A/B series probes meet the IEC-751 requirements of isolation resistance by several hundred percent.

## The final quality-certificate-check

Upon completion of every certificate, after final calibration of the probe, examination and approval cycles are performed according to our established procedures. The critical verification is to ensure that the difference between the initial and the final 0°C (32°F) measurement on the certificate meets our minimum tolerance. These requirements are based on a vast amount of data, which has been evaluated statistically. This value indicates if the probe has a sufficient long-term stability.

AMETEK also checks that the linearization coefficients have values that correlate to an acceptable curve sequence in accordance with our requirements.

## Certification

The final documentation on the probe is the calibration certificate.

The JOFRA STS probes can be delivered with either an accredited certificate or a traceable certificate.

In some cases, the customer may prefer to calibrate the probe. It is then possible to purchase the probe without any certification.

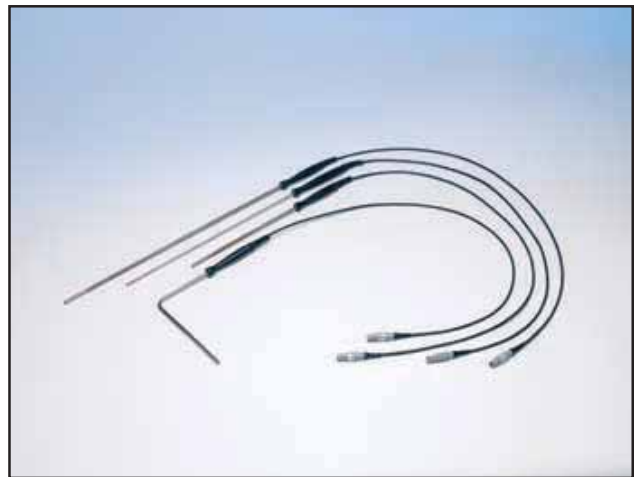

# JOFRA™ STS-100 A/B

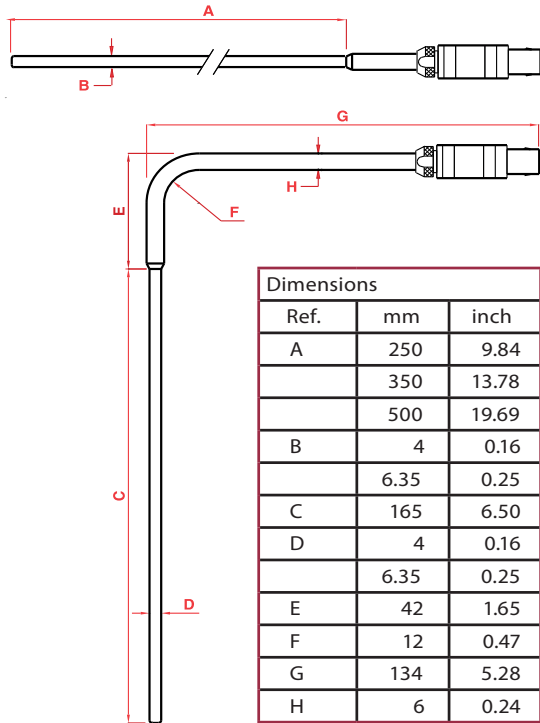

## STANDARD DELIVERY

- STS-100 A/B probe
- Cable - according to order number
- Accredited certificate, points: -45, -20, 0, 50, 100, 200, 320, 450 and 650°C
- 90° angled probe: Plastic carrying case with foam insert
- Straight probes: Aluminium case with foam insert
- User manual

## ACCESSORIES

- |                   |                                      |
|-------------------|--------------------------------------|
| 65-PT100-LL-CABLE | Cable 2 m (6.6 ft.) + LEMO to LEMO   |
| 65-PT100-LB-CABLE | Cable 2 m (6.6 ft.) + LEMO to banana |
| 122801            | Cable 0.5 m (1.6 ft.) LEMO to LEMO   |

## COMPATIBLE JOFRA INSTRUMENTS

The JOFRA STS-100 probes can be used with the following JOFRA instruments:

- JOFRA DTI-1000, spec. sheet no. SS-CP-2290
- JOFRA DTI050, spec. sheet no. SS-CP-2295
- JOFRA ATC series, spec. sheet no. SS-CP-2285
- JOFRA ASC300, spec. sheet no. SS-CP-2350
- JOFRA AMC900, spec. sheet no. SS-CP-2380

See the above-mentioned specification sheets and further information about the JOFRA instruments at [www.jofra.com](http://www.jofra.com)

## SPECIFICATIONS STS-100 A / B

### Temperature range

All probes ..... -150 to 650°C / -238 to 1202°F

### Accuracy

Hysteresis <sup>1)</sup> @0°C / 32°F ..... 0.01°C / 0.02°F  
 Long term stability <sup>2)</sup> @0°C / 32°F ..... typ. 0.014°C / 0.025°F  
 Repeatability <sup>1)</sup> ..... 0.002°C / 0.0036°F

Note 1: When used in the range -80 to 650°C / -112 to 1202°F.

Note 2: When exposed to 650°C / 1202°F for 100 h. Stability will depend on actual use of the sensor.

### Sensing element

Type ..... Pt100  
 Nominal resistance@0°C / 32°F ..... 100   
 Length ..... 40 mm / 1.6 in  
 Temperature coefficient ..... <sub>100</sub> = 0.00385 1/°C

### Minimum immersion depth

STS-100 A (4 mm / 0.16 in): ..... 100 mm / 3.9 in  
 STS-100 B (6.35 mm / 0.25 in): ..... 110 mm / 4.3 in

### Self-heating effect

0.06°C/mW / 0.108°F/mW

### Response time

STS-100 A (4 mm / 0.16 in): <sub>0.5</sub> (50%) ..... 8 seconds  
 STS-100 A (4 mm / 0.16 in): <sub>0.9</sub> (90%) ..... 26 seconds  
 STS-100 B (6.35 mm / 0.25 in): <sub>0.5</sub> (50%) ..... 18 seconds  
 STS-100 B (6.35 mm / 0.25 in): <sub>0.9</sub> (90%) ..... 44 seconds

Liquid in motion v=0.4m/s.

### Electrical connections

Cable ..... 4 wire + shield  
 Connection ..... LEMO goldplated

### Insulation resistance

@ 23°C / 73°F ..... 100 Gohm  
 @ 650°C / 1202°F ..... 70 Mohm

### Outer tube

Inconel 600

### Operating conditions

(Probe, connection, and cable) ..... Max. 70°C / 158°F  
 Storage temperature ..... -20 to 70 °C / -4 to 158 °F  
 Humidity ..... 0 to 90% RH  
 Protection class (connectors) ..... DIN 40050 IP-50

### Shipping dimensions - including carrying case

Straight probes, L x W x H .....  
 ..... 750 x 140 x 140 mm / 29.5 x 5.5 x 5.5 in  
 90° angled probe, L x W x H .....  
 ..... 220 x 250 x 60 mm / 8.7 x 9.8 x 2.4 in

### Shipping weight including packing

Straight probes ..... 1.9 kg / 4.2 lb  
 90° angled probe ..... 550 g / 1.2 lb



**JOFRA DTI050 AND STS-100 A / B**

Order No.	Description
DTI050	Temperature indicator DTI050 Temperature Indicator
G	Certification DTI050
H	NIST traceable certificate (standard) Accredited certificate
100	STS reference sensor Pt100 reference probe, solid, -150 to 650°C (-238 to 1207°F)
A	Diameter of the probe
B	Overall diameter 4 mm (0.16 in) Overall diameter 6.35 mm (0.25 in)
250	Shape and length
350	Straight probe, 250 mm (9.8 in) in alu case
500	Straight probe, 350 mm (13.8 in) in alu case
901	Straight probe, 500 mm (19.7 in) in alu case 90° angled probe, 207 mm (8.1 in) in plastic case
F	Calibration certificate
H	NPL traceable calibration certificate on sensor
FS	Accredited calibration certificate on sensor (standard)
HS	NPL traceable system calibration certificate Accredited system calibration certificate
C	Options
X	System carrying case (max. 350 mm. probe) No option used

DTI050G100A250HXH  
Sample order number  
JOFRA DTI050 temperature indicator with NIST traceable calibration certificate and 4 mm STS-100 Reference sensor, Straight 250 mm. with accredited calibration certificate and 2 m cable + REDEL connector for DTI050.

**JOFRA STS-100 A / B**

Order no.	Description
STS100	Base model number Pt100 reference probe, solid, -150 to 650°C (-238 to 1207°F)
A	Diameter of the probe
B	Overall diameter 4 mm (0.16 in) Overall diameter 6.35 mm (0.25 in)
250	Shape and length
350	Straight probe, 250 mm (9.8 in) in alu case
500	Straight probe, 350 mm (13.8 in) in alu case
901	Straight probe, 500 mm (19.7 in) in alu case 90° angled probe, 207 mm (8.1 in) in plastic case
A	Cable length and termination
B	Cable 0.5 m (1.6 ft.) + LEMO connector
C	Cable 2 m (6.6 ft.) + LEMO connector
D	Cable 2 m (6.6 ft.) + Banana plug connectors Cable 2 m (6.6 ft.) + REDEL connector for DTI050
H	Calibration certificate
F	Accredited calibration certificate (Standard)
I	NPL traceable calibration certificate No certificate - Annealed only (Useless without calibration certificate/coefficients)

STS100 A 901 D H  
Sample order number  
4 mm STS-100 Reference sensor angled 90°, Cable length 0.5 m (1.6 ft.) with REDEL connector for DTI050 and accredited calibration certificate.

**JOFRA™ STS-102 A**

JOFRA has also designed a special cable type reference sensor, the STS-102 A. Due to the small size and flexible connection, the design permits positioning of the sensor throughout the depth of the well in a dry-block, eg. under a sanitary flange.

The reference sensor must be placed at the same level and in parallel with the sensor-under-test as indicated in the illustration to the right. The illustration shows calibration of a sanitary sensor. The sensor is in contact with the insert.

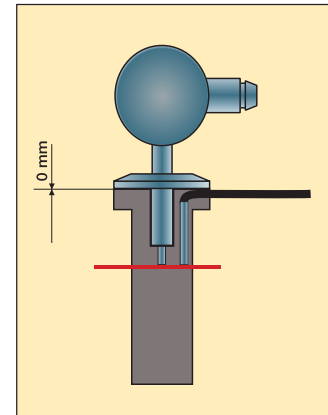

Below you see the custom insert and STS-102 A reference sensor placed in a JOFRA ATC-156 B dry-block calibrator. On the right, the sanitary sensor has been fitted into the insert and is ready for calibration. Note that the design makes room for the reference sensor cable.



**STANDARD DELIVERY**

- JOFRA STS-102 A probe
- Plastic carrying case with foam insert
- Accredited certificate, points: -45, -20, 0, 50, 100 and 155°C
- User manual
- Calibration tube

**COMPATIBLE JOFRA INSTRUMENTS**

The JOFRA STS-100 probes can be used with the following JOFRA instruments:

JOFRA DTI-1000, spec. sheet no. SS-CP-2290

JOFRA DTI050, spec. sheet no. SS-CP-2295

JOFRA ATC series, spec. sheet no. SS-CP-2285

JOFRA ASC300, spec. sheet no. SS-CP-2350

JOFRA AMC900, spec. sheet no. SS-CP-2380

See the above-mentioned specification sheets and further information about the JOFRA instruments at [www.jofra.com](http://www.jofra.com)

See specifications and ordering information at the next page (page 10).

**SPECIFICATIONS STS-102 A**

**Temperature range**

All probes ..... -50 to 155°C / -58 to 311°F

**Accuracy**

Hysteresis @0°C / 32°F ..... 0.01°C / 0.018°F  
 Long term stability 1) @0°C / 32°F ..... typ. 0.025°C / 0.045°F  
 Repeatability ..... 0.002°C / 0.0036°F

Note 1: When exposed to 155°C (311°F) for 200 hours, stability will depend on actual use of the sensor.

**Sensing element**

Type ..... Pt100  
 Nominal resistance@0°C / 32°F ..... 100  $\square$   
 Length ..... 30 mm / 1.18 in  
 Temperature coefficient .....  $\square_{100}$  = 0.00385 1/°C

**Minimum immersion depth**

30 mm / 1.18 in

**Self-heating effect**

0.06°C/mW / 0.108°F/mW

**Response time**

$\square_{0.9}$  (90%) ..... 16 seconds

Measured in water

**Electrical connections**

Cable ..... 4 wire + shield  
 Connection ..... LEMO goldplated

**Insulation resistance**

@ 23°C / 73°F ..... 3 Gohm

**Outer tube**

AISI 316TI

**Operating conditions**

(Probe, connection, and cable) ..... Max. 70°C / 158°F  
 Storage temperature ..... -20 to 70 °C / -4 to 158 °  
 Humidity ..... 0 to 90% RH  
 Protection class (connectors) ..... DIN 40050 IP-50

**Shipping dimensions**

STS-102 A probe (including carrying case):  
 L x W x H ..... 220 x 250 x 60 mm / 8.7 x 9.8 x 2.4 in  
 Shipping weight including packing  
 STS-102 A probe ..... 550 g / 1.2 lb



**JOFRA DTI050 AND STS-102 A**

Order no.	Description
DTI050	Temperature Indicator DTI050 Temperature Indicator
	Certification DTI050 NIST traceable certificate (standard) Accredited certificate
	102 STS reference sensor Pt100 reference probe, cable, -50 to 155°C (-58 to 311°F)
	A Diameter of the probe Overall diameter 4 mm (0.16 in)
	030 Shape and length Short sensor 30 mm / 1.18 in in plastic case
	F Calibration certificate NPL traceable calibration certificate on sensor Accredited calibration certificate on sensor (standard)
	H Accredited calibration certificate on sensor (standard)
	FS NPL traceable system calibration certificate Accredited system calibration certificate
	HS Accredited system calibration certificate
	Options
	C System carrying case (max. 350 mm, probe)
	X No option used
DTI050G102A030HXX	Sample order number JOFRA DTI050 temperature indicator with NIST traceable calibration certificate and 4 mm STS-100, short 30 mm reference sensor with accredited calibration certificate and 1 m cable + REDEL connector for DTI050.

**JOFRA STS-102 A**

Order no.	Description
STS102	Base model number Pt100 reference probe, cable, -50 to 155°C (-58 to 311°F)
	A Diameter of the probe Overall diameter 4 mm (0.16 in)
	030 Shape and length Short sensor 30 mm / 1.18 in in a plastic case
	S Cable length and termination Cable 1 m (3.3 ft.), Integrated Teflon cable, LEMO connector
	D Cable 1 m (3.3 ft.) + REDEL connector for DTI050
	H Calibration certificate Accredited calibration certificate (standard)
	F NPL traceable calibration certificate
	I No certificate - Annealed only (Useless without calibration certificate / co-efficients)
STS102 A 030 D H	Sample order number 4 mm STS-102, short 30 mm reference sensor, Cable length 1 m (3.3 ft.) with REDEL connector for DTI050 and accredited calibration certificate.

# JOFRA™ STS-050 A/B

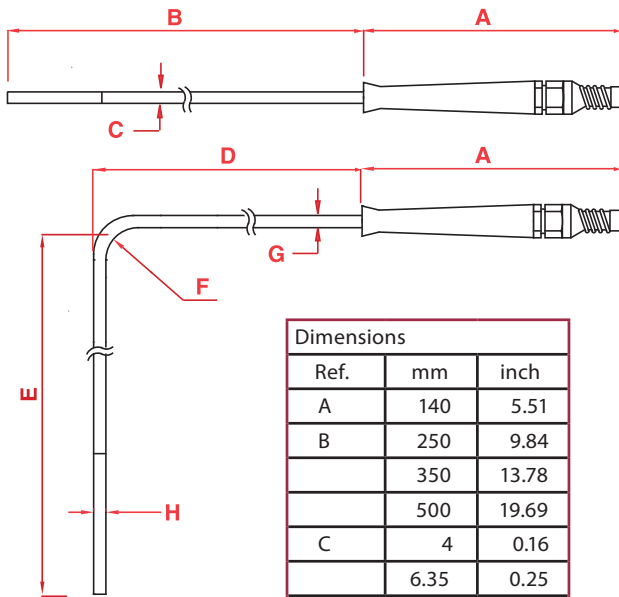

Dimensions		
Ref.	mm	inch
A	140	5.51
B	250	9.84
	350	13.78
	500	19.69
C	4	0.16
	6.35	0.25
D	100	3.93
E	200	7.87
F	12	0.47
G	6.35	0.25
H	6.35	0.25

## STANDARD DELIVERY

- JOFRA STS-050 A/B probe with handle
- Cable - according to order number
- Traceable certificate, points: -45, -20, 0, 100, 250 and 400°C
- 90° angled probe: Carton case with foam insert
- Straight probes: Carton case with foam insert
- User manual

## COMPATIBLE JOFRA INSTRUMENTS

The JOFRA STS-050 probes can be used with the following JOFRA instruments:  
 JOFRA DTI050, spec. sheet no. SS-CP-2295

See the above-mentioned specification sheets and further information about the JO FRA instruments at [www.jofra.com](http://www.jofra.com)

## SPECIFICATIONS STS-050 A / B

### Temperature range

All probes ..... -50 to 400°C / -58 to 752°F

### Accuracy

Hysteresis <sup>1)</sup> @0°C / 32°F ..... 0.01°C / 0.02°F  
 Long term stability <sup>2)</sup> @0°C / 32°F ..... typ. 0.014°C / 0.025°F  
 Repeatability <sup>1)</sup> ..... 0.005°C / 0.009°F  
 1) when used in the range -50 to 400°C / -58 to 752°F.  
 2) when exposed to 400°C / 752°F for 100 h. Stability will depend on actual use of the sensor.

### Sensing element

Type ..... Pt100  
 Nominal resistance@0°C / 32°F ..... 100  $\square$   
 Length ..... 22 mm / 0.9 in  
 Temperature coefficient .....  $\square_{100}$ =0.00385 1/°C

### Minimum immersion depth

STS-050 A (4 mm / 0.16 in): ..... 60 mm / 2.36 in  
 STS-050 B (6.35 mm / 0.25 in): ..... 90 mm / 3.54 in

### Self-heating effect

0.04°C/mW / 0.07°F/mW

### Response time

STS-050 A (4 mm / 0.16 in):  $\square_{0.5}$  (50%) ..... 7 seconds  
 STS-050 A (4 mm / 0.16 in):  $\square_{0.9}$  (90%) ..... 17 seconds  
 STS-050 B (6.35 mm / 0.25 in):  $\square_{0.5}$  (50%) ..... 11 seconds  
 STS-050 B (6.35 mm / 0.25 in):  $\square_{0.9}$  (90%) ..... 30 seconds

Liquid in motion v=0.4m/s.

### Electrical connections

Cable ..... 4 wire  
 Connection ..... REDEL goldplated

### Insulation resistance

@ 23°C / 73°F ..... 100 Gohm  
 @ 400°C / 752°F ..... 70 Mohm

### Outer tube

AISI 316

### Operating conditions

(Probe, connection, and cable) ..... Max. 70°C / 158°F  
 Storage temperature ..... -20 to 70 °C / -4 to 158 °F  
 Humidity ..... 0 to 90% RH  
 Protection class ..... DIN 40050 IP-50

See ordering information at the next page (page 12).

## ORDERING JOFRA DTI050 AND STS-050

Order No.	Description
DTI050	Temperature Indicator DTI050 Temperature Indicator
	Certification
G	NIST traceable certificate (standard)
H	Accredited certificate
	STS reference sensor
050	Pt100 reference probe, solid, with handle, -50 to 400°C (-58 to 752°F)
	Diameter of the probe
A	Overall diameter 4 mm (0.16 in)
B	Overall diameter 6.35 mm (0.25 in)
	Shape and length
250	Straight probe, 250 mm (9.8 in)
350	Straight probe, 350 mm (13.8 in)
500	Straight probe, 500 mm (19.7 in)
901	90° angled probe, 207 mm (8.1 in) (only version B with Ø6.35 mm)
	Calibration certificate
F	NPL traceable calibration certificate on sensor (standard)
H	Accredited calibration certificate on sensor
FS	NPL traceable system calibration certificate
HS	Accredited system calibration certificate
	Options
C	System carrying case (max. 350 mm. straight probe)
X	No option used

DTI050G050A250FX Sample order number  
JOFRA DTI050 temperature indicator with NIST traceable calibration certificate and 4 mm STS-050 Reference sensor, Straight 250 mm. with NPL traceable calibration certificate and 2 m cable + REDEL connector for DTI050.

## ORDERING JOFRA STS-050

Order no.	Description
STS050	Base model number Pt100 reference probe, solid, with handle, -50 to 400°C (-58 to 752°F)
	Diameter of the probe
A	Overall diameter 4 mm (0.16 in)
B	Overall diameter 6.35 mm (0.25 in)
	Shape and length
250	Straight probe, 250 mm (9.8 in) delivered in carton
350	Straight probe, 350 mm (13.8 in) delivered in carton
500	Straight probe, 500 mm (19.7 in) delivered in carton
901	90° angled probe, 207 mm (8.1 in) delivered in carton
	Cable length and termination
D	Cable 2 m (6.6 ft.) + REDEL connector for DTI050
	Calibration certificate
H	Accredited calibration certificate
F	NPL traceable calibration certificate (standard)

STS050 A 250 D F Sample order number  
4 mm STS-050 Reference probe, Straight 250 mm, Cable length 2 m (6.6 ft.) with REDEL connector for DTI050 and NPL traceable calibration certificate



AMETEK Calibration Instruments offers a complete range of calibration equipment for temperature, pressure, and signal - including calibration software.

JOFRA Temperature Calibrators  
Portable precision thermometer. Dry-block and liquid bath calibrators: 4 series, with more than 20 models - featuring speed, portability, accuracy and advanced documenting functions with JOFRACAL temperature calibration software.

JOFRA Pressure Calibrators  
Convenient electronic systems ranging from -1 to 700 bar (25 inHg to 10,000 psi) - multiple choices of pressure ranges, pumps and accuracies, fully temperature-compensated for problem-free and accurate field use.

JOFRA Signal Calibrators  
Process signal measurement and simulation for easy control loop calibration and measurement tasks - from handheld field instruments for multi or single signals to laboratory reference level bench top instruments.

JOFRA / JF Marine Calibrators  
A complete range of calibration equipment for temperature, pressure and signal, approved for marine use.

FP Temperature Sensors  
A complete range of temperature sensors for industrial and marine use.

...because calibration is  
a matter of confidence



*The Right Source For Your Test & Measurement Needs*

2232 Verus Street Suite D San Diego CA 92154 USA  
Toll Free: 866.363.6634 Tel: 619.429.4545 Fax: 619.374.7012  
Email: sales@calright.com <http://www.calright.com>